



PRIUS PRIME

PRIUS PHV

**Plug-in Hybrid**

*Gasoline-Electric*

*Hybrid Synergy Drive*

***HYBRID VEHICLE  
DISMANTLING  
MANUAL***

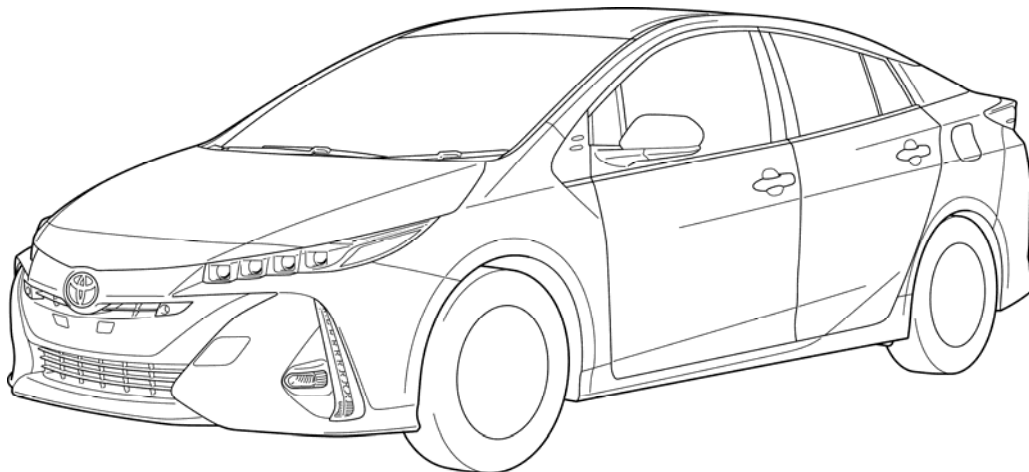

## Foreword

This guide was developed to educate and assist dismantlers in the safe handling of Toyota PRIUS PRIME, PRIUS PHV gasoline-electric hybrid vehicles. PRIUS PRIME, PRIUS PHV dismantling procedures are similar to other non-hybrid Toyota vehicles with the exception of the high voltage electrical system. It is important to recognize and understand the high voltage electrical system features and specifications of the Toyota PRIUS PRIME, PRIUS PHV, as they may not be familiar to dismantlers.

High voltage electricity powers the A/C compressor, electric motor, generator, and inverter/converter. All other conventional automotive electrical devices such as the head lights, radio, and gauges are powered from a separate 12 Volt auxiliary battery. Numerous safeguards have been designed into the PRIUS PRIME, PRIUS PHV to help ensure the high voltage, approximately 351.5 Volt, Lithium-ion (Li-ion) Hybrid Vehicle (HV) battery pack is kept safe and secure in an accident.

The Li-ion HV battery pack contains sealed batteries that are similar to rechargeable batteries used in some battery operated power tools and other consumer products. The electrolyte is absorbed in the cell plates and will not normally leak out even if the battery is cracked. In the unlikely event the electrolyte does leak, it can be easily neutralized with a dilute boric acid solution or vinegar.

High voltage cables, identifiable by orange insulation and connectors, are isolated from the metal chassis of the vehicle.

Additional topics contained in the guide include:

- Toyota PRIUS PRIME, PRIUS PHV identification.
- Major hybrid component locations and descriptions.

By following the information in this guide, dismantlers will be able to handle PRIUS PRIME, PRIUS PHV hybrid-electric vehicles as safely as the dismantling of a conventional gasoline engine automobile.

© 2016 Toyota Motor Corporation

All rights reserved. This book may not be reproduced or copied, in whole or in part, without the written permission of Toyota Motor Corporation.

# Table of Contents

<b><u>About the PRIUS PRIME, PRIUS PHV</u></b> .....	<b><u>1</u></b>
<b><u>PRIUS PRIME, PRIUS PHV Identification</u></b> .....	<b><u>2</u></b>
<u>Exterior</u> .....	<u>3</u>
<u>Interior</u> .....	<u>4</u>
<u>Engine Compartment</u> .....	<u>5</u>
<b><u>Hybrid Component Locations &amp; Descriptions</u></b> .....	<b><u>6</u></b>
<u>Specifications</u> .....	<u>7</u>
<b><u>Hybrid Synergy Drive Operation</u></b> .....	<b><u>8</u></b>
<u>Vehicle Operation</u> .....	<u>8</u>
<b><u>Hybrid Vehicle (HV) Battery Pack and Auxiliary Battery</u></b> .....	<b><u>9</u></b>
<u>HV Battery Pack</u> .....	<u>9</u>
<u>Components Powered by the HV Battery Pack</u> .....	<u>9</u>
<u>HV Battery Pack Recycling</u> .....	<u>10</u>
<u>Auxiliary Battery</u> .....	<u>10</u>
<b><u>High Voltage Safety</u></b> .....	<b><u>11</u></b>
<u>High Voltage Safety System</u> .....	<u>11</u>
<u>Service Plug Grip</u> .....	<u>12</u>
<b><u>Precaution to be observed when dismantling the vehicle</u></b> .....	<b><u>13</u></b>
<u>Necessary Items</u> .....	<u>13</u>
<b><u>Spills</u></b> .....	<b><u>14</u></b>
<b><u>Dismantling the vehicle</u></b> .....	<b><u>15</u></b>
<b><u>Removal of HV battery</u></b> .....	<b><u>20</u></b>



## About the PRIUS PRIME, PRIUS PHV

The PRIUS PRIME, PRIUS PHV contains a gasoline engine, an electric motor, and a developed large capacity Li-ion battery. It is the Toyota hybrid that allows the HV battery to be plugged-in and charged by an external power source.

The two hybrid power sources are stored on board the vehicle:

1. Gasoline stored in the fuel tank for the gasoline engine.
2. Electricity stored in a large capacity externally chargeable high voltage Hybrid Vehicle (HV) battery assembly for the electric motor.

Depending on the driving conditions, one or both sources are used to power the vehicle. The following illustration demonstrates how the Prius Plug-in hybrid operates in various driving modes.

### EV (Electric Vehicle) Mode:

- ❶ Utilizing the charge cable assembly connected to a 240 (120) Volt outlet, the vehicle's HV battery can be charged within 2.0 (5.5) hours. (for North America)

Utilizing the charge cable assembly connected to a 230 Volt outlet, the vehicle's HV battery can be charged within 3.5 hours. (for Europe)

- ❷ When the HV battery is sufficiently charged, the vehicle will basically run on the power of the motor.
- ❸ If the vehicle exceeds 135 km/h or accelerates suddenly when traveling in plug-in EV mode, the gasoline engine and motor work together to power the vehicle.

### HV (Hybrid Vehicle) Mode:

- ❹ During light acceleration at low speeds, the vehicle is powered by the electric motor. The gasoline engine is shut off.
- ❺ During normal driving, the vehicle is powered mainly by the gasoline engine. The gasoline engine also powers the generator to recharge the battery assembly and to drive the motor.
- ❻ During full acceleration, such as climbing a hill, both the gasoline engine and the electric motor power the vehicle.
- ❼ During deceleration, such as when braking, the vehicle regenerates the kinetic energy from the front wheels to produce electricity that recharges the battery assembly.
- ❽ While the vehicle is stopped, the gasoline engine and electric motor are off, however the vehicle remains on and operational.

❶ Plug-in Charging    ❷ Normal Driving    ❸ Hard Acceleration

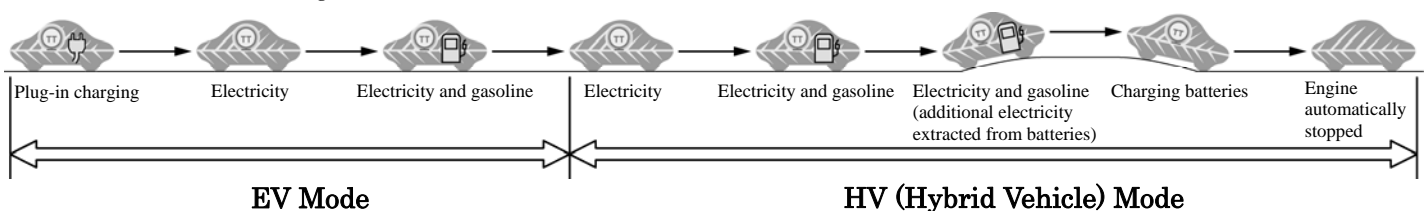

## **PRIUS PRIME, PRIUS PHV Identification**

In appearance, the PRIUS PRIME, PRIUS PHV is a 5-door sedan. Exterior, interior, and engine compartment illustrations are provided to assist in identification.

The alphanumeric 15 character Vehicle Identification Number (VIN) is provided on the floor under the right side front seat, left side windshield cowl and left side B pillar.

Example VIN:

JTDKARFP3000101, JTDKA3FP3000101 or JTDKA3FP3000001

A PRIUS PRIME, PRIUS PHV is identified by the first 8 alphanumeric characters **JTDKARFP** or **JTDKA3FP**.

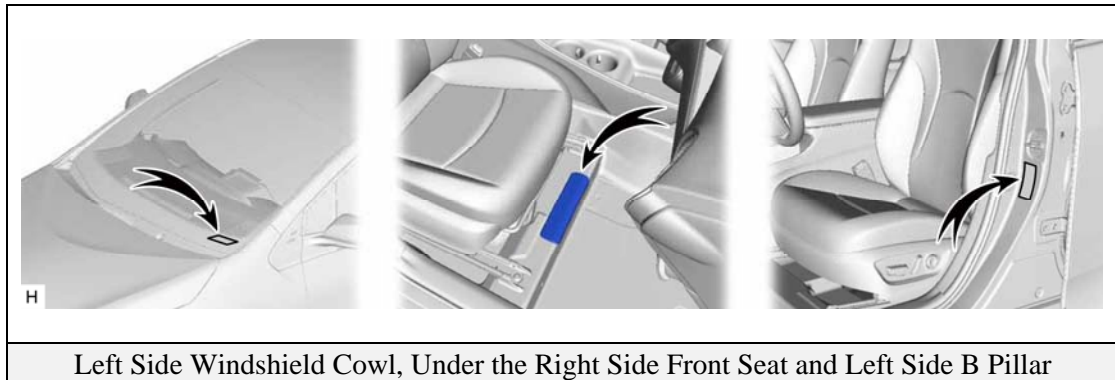

## PRIUS PRIME, PRIUS PHV Identification (Continued)

### Exterior

- ❶ PRIUS PRIME, PRIUS PHV logo on the luggage compartment door.
- ❷  logos on the luggage compartment door and each front fender.
- ❸ Gasoline fuel filler door located on the left side rear quarter panel.
- ❹ Charge inlet door located on the right side rear quarter panel.

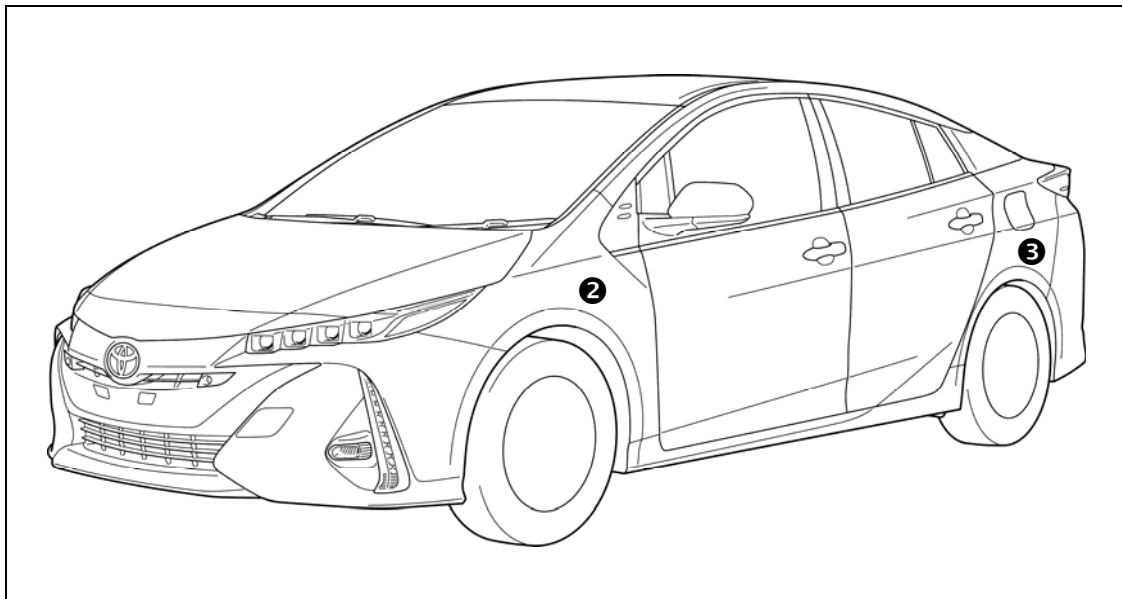

Exterior Front and Left Side View

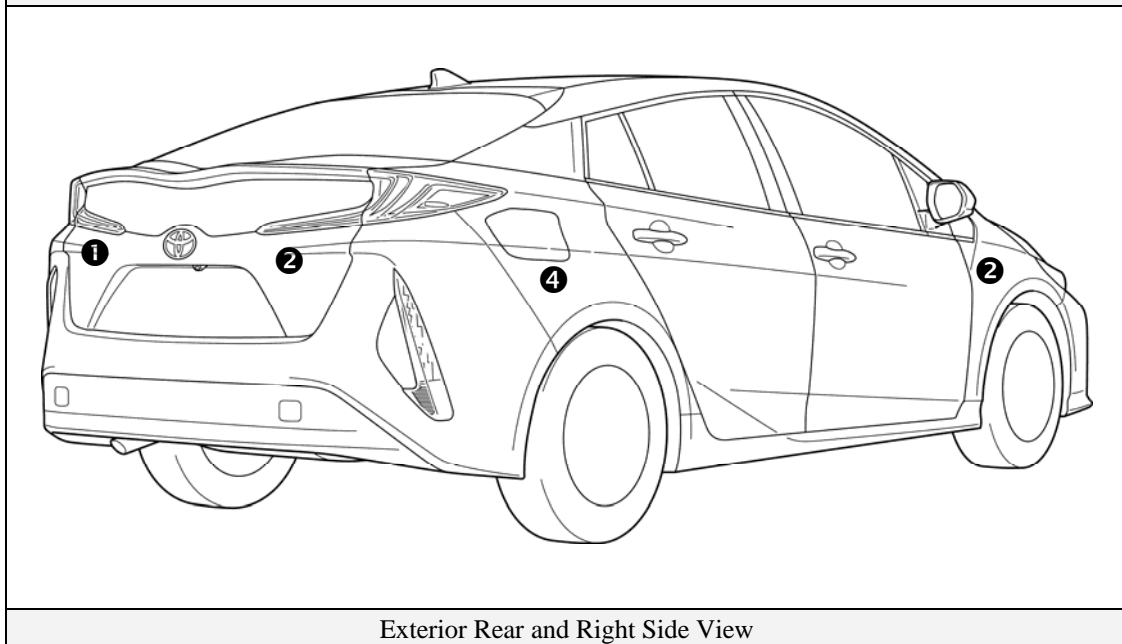

Exterior Rear and Right Side View

## PRIUS PRIME, PRIUS PHV Identification (Continued)

### Interior

- 5 The instrument cluster (**READY** indicator, shift state indicators and warning lights) located in center of the dash and near the base of the windshield.

**Notice:**

If the vehicle is shut off, the instrument cluster gauges will be “blacked out”, not illuminated.

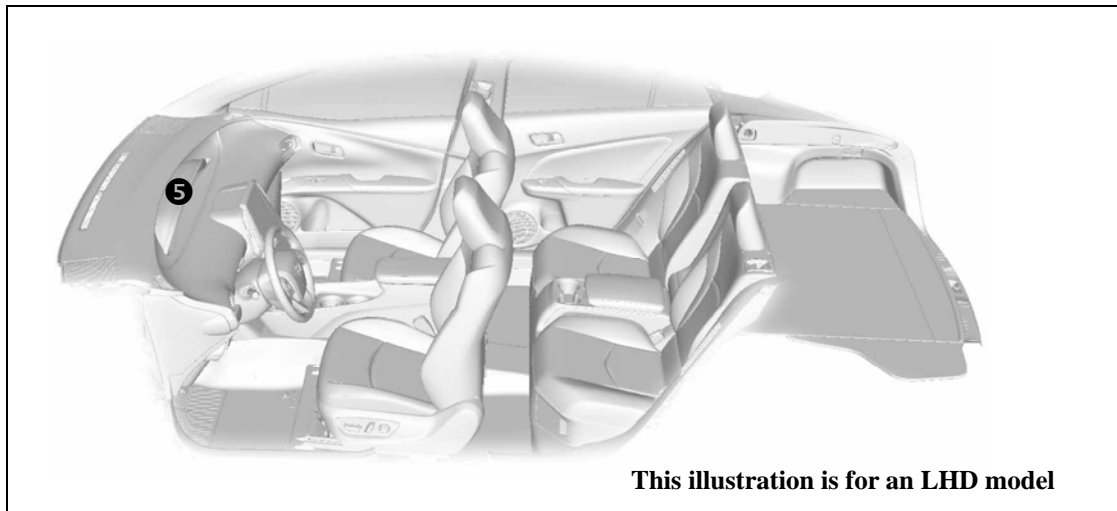

Interior View

5

for LHD:



for RHD:



Combination Meter View



## PRIUS PRIME, PRIUS PHV Identification (Continued)

### Engine Compartment

- ⑥ 1.8-liter aluminum alloy gasoline engine.
- ⑦ Orange colored high voltage power cables.

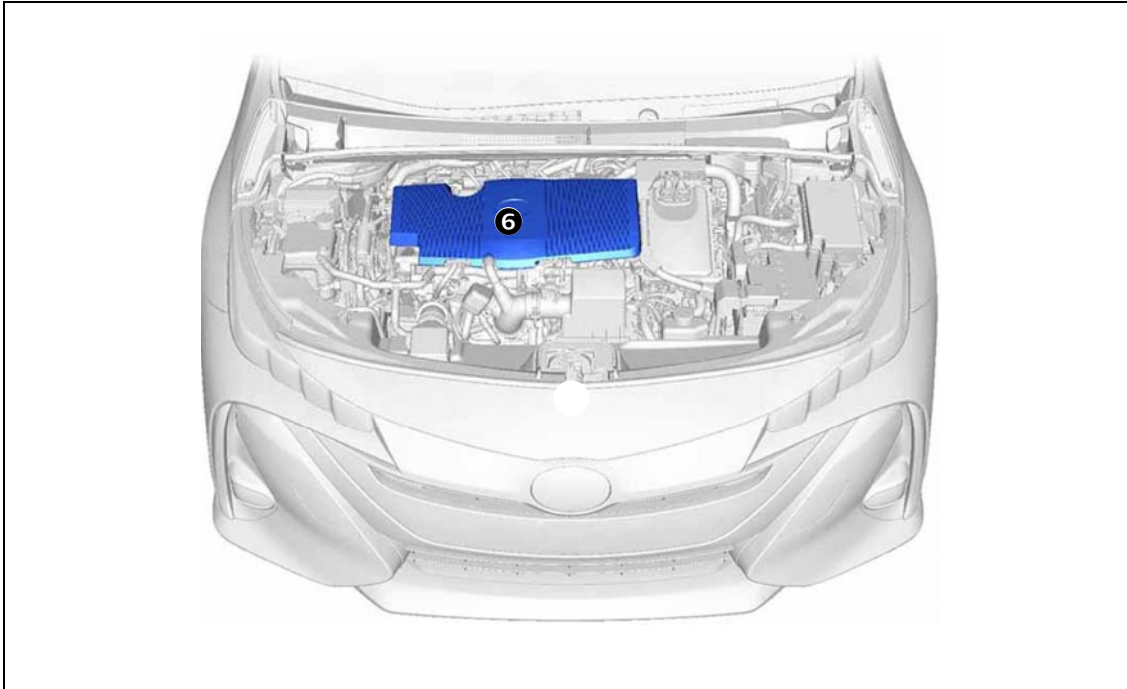

Engine Compartment View

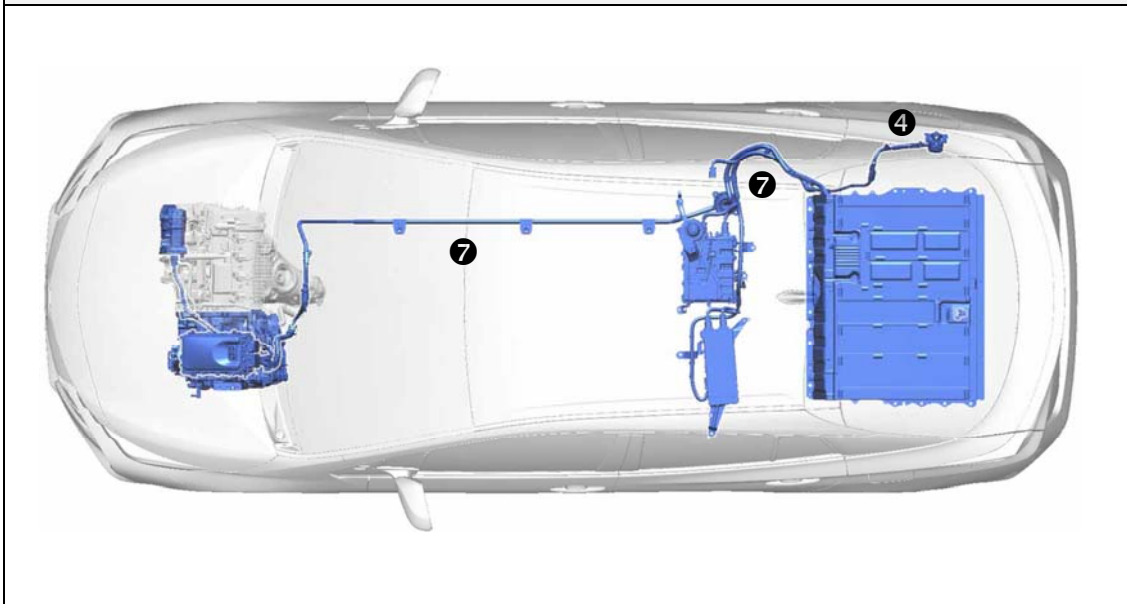

Power Cables

## Hybrid Component Locations & Descriptions

Component		Description
12 Volt Auxiliary Battery ❶		Supplies electricity to the electrical components.
Hybrid Vehicle (HV) Battery Pack ❷		<ul style="list-style-type: none"> <li>Supplies electrical power to MG1 and MG2 in accordance with the driving conditions of the vehicle.</li> <li>Recharged by MG1 and MG2 in accordance with the SOC and the driving conditions of the vehicle.</li> </ul>
Power Cables ❸		Connects the HV battery, inverter with converter assembly, hybrid vehicle transaxle assembly and compressor with motor assembly.
Inverter/ Converter ❹	DC-DC Converter ❺ for 12 Volt Auxiliary Battery	Steps down the HV battery nominal voltage of DC 351.5 V to approximately DC 14 V in order to supply electricity to the electrical components, as well as to recharge the auxiliary battery.
	Motor Generator ECU	Controls the inverter and boost converter in accordance with the signals received from the hybrid vehicle control ECU, thus operating MG1 and MG2 as either a generator or motor.
	Boost Converter	Boosts the HV battery nominal voltage of DC 351.5 V up to a maximum voltage of DC 600 V and vice versa (steps down DC 600 V to DC 351.5 V).
	Inverter	Converts the direct current from the boost converter into alternating current for MG1 and MG2, and vice versa (from AC to DC).
Gasoline Engine ❻		Is a high-expansion ratio Atkinson cycle engine which is compatible with the hybrid system and which generates drive force for driving and energy for electricity generation.
Electric Motor ❼		<ul style="list-style-type: none"> <li>MG2, which is driven by electrical power from MG1 and the HV battery, generates motive force for the drive wheels.</li> <li>During braking, or when the accelerator pedal is not depressed, it generates high-voltage electricity to recharge the HV battery.</li> </ul>
Electric Generator ❽		<ul style="list-style-type: none"> <li>MG1, which is driven by the engine, generates high-voltage electricity in order to operate MG2 and charge the HV battery. Also, it functions as a starter to start the engine.</li> <li>Supports MG2 using power supplied from the HV battery assembly to increase driving torque.</li> </ul>
A/C Compressor (with inverter) ❾		Is driven at a speed calculated by the air conditioning amplifier assembly, receives drive requests from the hybrid vehicle control ECU and takes in, compresses and discharges refrigerant.
Fuel Tank and Fuel Line ❿		The fuel tank provides gasoline via a fuel line to the engine. The fuel line is routed along the left side under the floor pan.

\*Numbers in the component column apply to the illustrations on the following page.

## Hybrid Component Locations & Descriptions (Continued)

### Specifications

- Gasoline Engine: 71 kW (96 HP), 1.8-liter Aluminum Alloy Engine
- Electric Motor: 53 kW (71 HP), Permanent Magnet Motor
- Transmission: Automatic Only
- HV Battery: 351.5 Volt Sealed Li-ion-Battery
- Curb Weight: 1,525 to 1,550 kg / 3,365 to 3,417 lbs
- Fuel Tank: 43 liters /11.4 gals
- Frame Material: Steel Unibody
- Body Material: Steel Panels, CFRP (for Luggage compartment door)
- Seating Capacity: 5 passenger

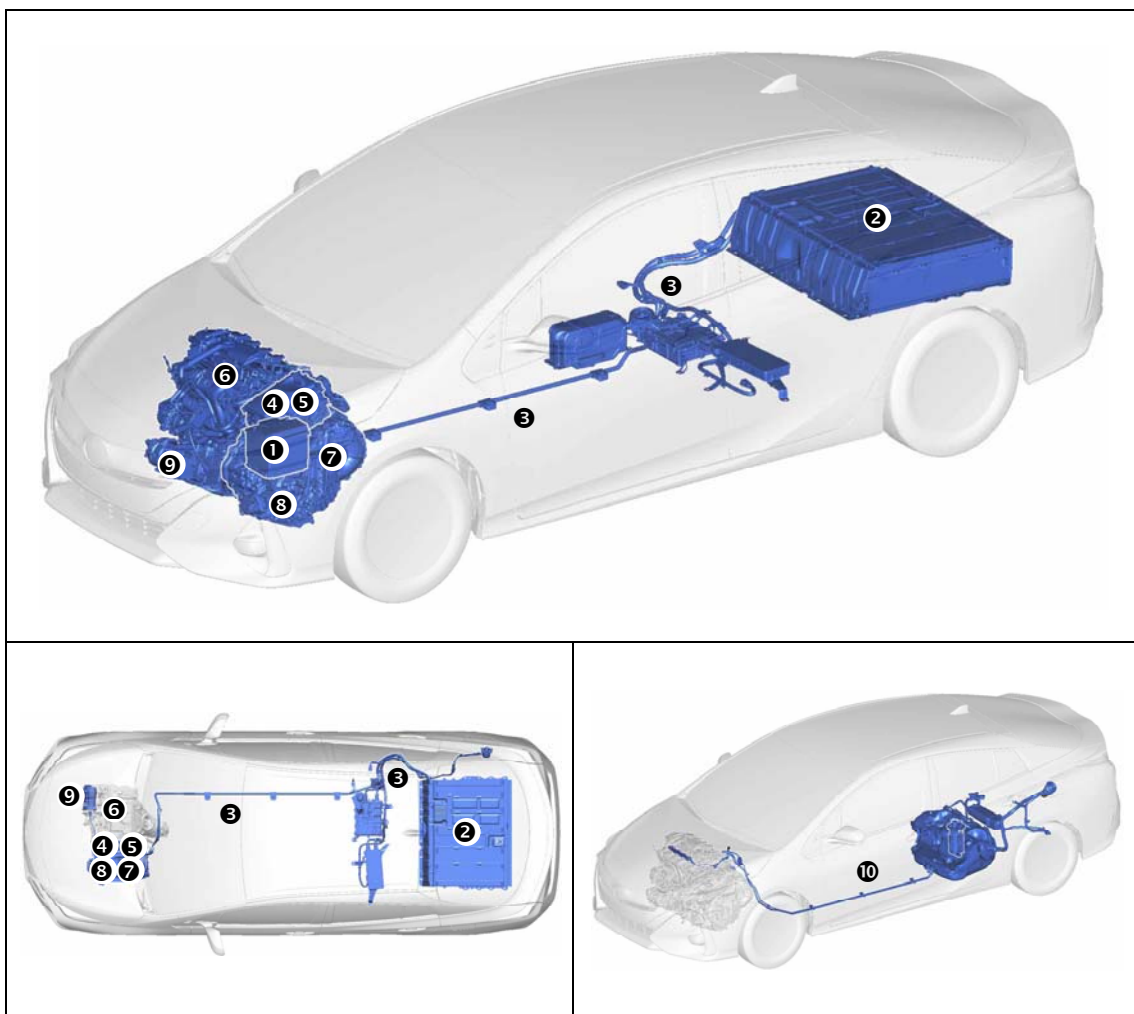

## Hybrid Synergy Drive Operation

Once the **READY** indicator is illuminated in the combination meter, the vehicle may be driven. However, the gasoline engine does not idle like a typical automobile and will start and stop automatically. It is important to recognize and understand the **READY** indicator provided in the instrument cluster. When illuminated, it informs the driver that the vehicle is on and operational even though the gasoline engine may be off and the engine compartment is silent.

### Vehicle Operation

- With the **PRIUS PRIME**, **PRIUS PHV**, the gasoline engine may stop and start at any time while the **READY** indicator is on.
- Never assume that the vehicle is shut off just because the engine is off. Always look for the **READY** indicator status. The vehicle is shut off when the **READY** indicator is off.

The vehicle may be powered by:

1. The electric motor only.
2. A combination of both the electric motor and the gasoline engine.

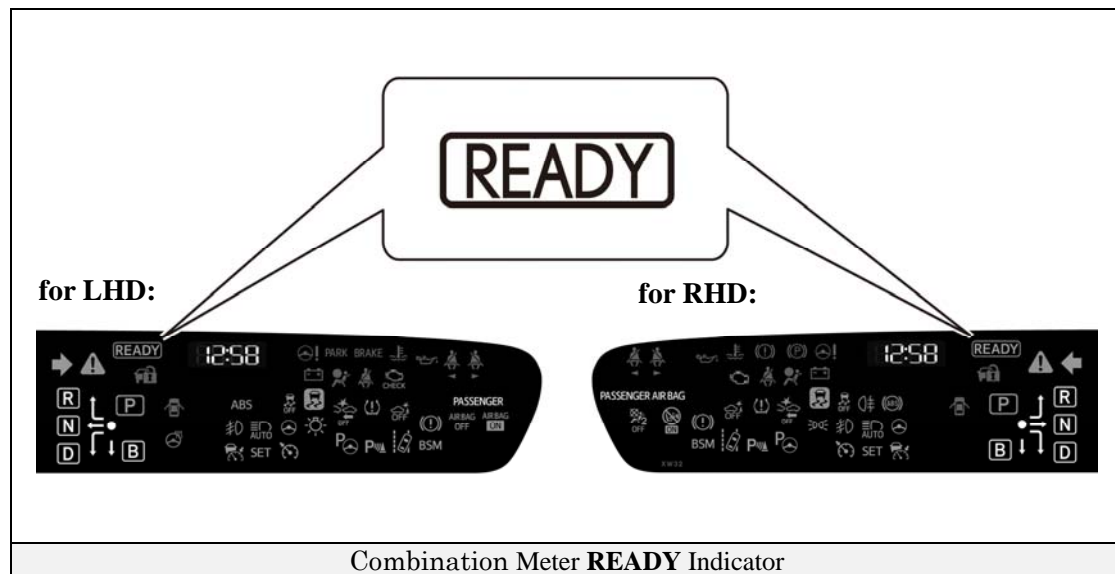

## Hybrid Vehicle (HV) Battery Pack and Auxiliary Battery

The PRIUS PRIME, PRIUS PHV features a high voltage Hybrid Vehicle (HV) battery pack that contains sealed Lithium-ion (Li-ion) battery cells.

### HV Battery Pack

- The HV battery pack is enclosed in a metal case and is rigidly mounted to the cabin area under the right side front seat. The metal case is isolated from high voltage and concealed by fabric covers in the cabin area.
- The HV battery pack consists of 95 low voltage (3.7 Volt) Li-ion battery cells connected in series to produce approximately 351.5 Volts. Each Li-ion battery cell is non-spillable and in a sealed case.
- The electrolyte used in the Li-ion battery cells is a flammable organic electrolyte. The electrolyte is absorbed into the battery cell separator and will not normally leak, even in a collision.

HV Battery Pack	
Battery pack voltage	351.5 V
Number of Li-ion battery cells in the pack	95
Li-ion battery cell voltage	3.7 V

### Components Powered by the HV Battery Pack

- Electric Motor
- Power Cables
- A/C Compressor
- Electric Generator
- Inverter/Converter
  - DC-DC Converter for 12 Volt Auxiliary Battery

## Hybrid Vehicle (HV) Battery Pack and Auxiliary Battery (Continued)

### HV Battery Pack Recycling

- The HV battery pack is recyclable. Contact either your Toyota Distributor as mentioned on HV battery Caution Label or the nearest Toyota dealer.

### Auxiliary Battery

- The PRIUS PRIME, PRIUS PHV also contains a sealed lead-acid 12 Volt battery. This 12 Volt auxiliary battery powers the vehicle electrical system similar to a conventional vehicle. As with other conventional vehicles, the auxiliary battery is grounded to the metal chassis of the vehicle.
- The auxiliary battery is located in the engine compartment area.

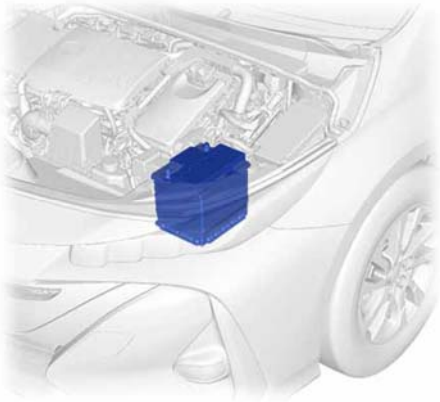
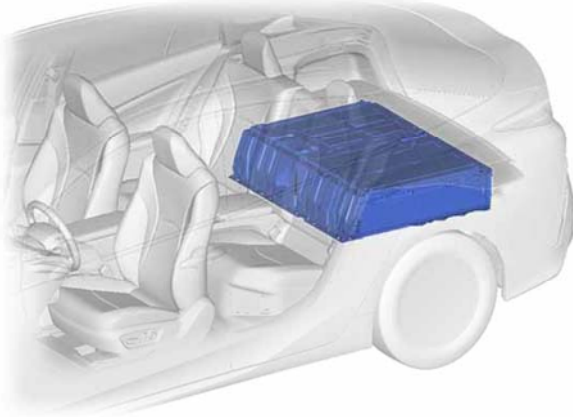
	
351.5 Volt HV Battery Pack	12 Volt Auxiliary Battery Mounted in Engine Compartment Area
	
HV Battery Pack Mounted in Luggage Compartment Area	

## High Voltage Safety

The HV battery pack powers the high voltage electrical system with DC electricity. Positive and negative orange colored high voltage power cables are routed from the battery pack, under the vehicle floor pan, to the inverter/converter. The inverter/converter contains a circuit that boosts the HV battery voltage from 351.5 to 600 Volts DC. The inverter/converter creates 3-phase AC to power the motor. Power cables are routed from the inverter/converter to each high voltage motors (electric motor and electric generator). The following systems are intended to help keep occupants in the vehicle and emergency responders safe from high voltage electricity:

### High Voltage Safety System

- A high voltage fuse ❶\* provides short circuit protection in the HV battery pack.
- Positive and negative high voltage power cables ❷\* connected to the HV battery pack are controlled by 12 Volt normally open relays ❸\*. When the vehicle is shut off, the relays stop electricity flow from leaving the HV battery pack.



#### **WARNING:**

- ***The high voltage system may remain powered for up to 10 minutes after the vehicle is shut off or disabled. To prevent serious injury or death from severe burns or electric shock, avoid touching, cutting, or opening any orange high voltage power cable or high voltage component.***

- Both positive and negative power cables ❷\* are insulated from the metal body. High voltage electricity flows through these cables and not through the metal vehicle body. The metal vehicle body is safe to touch because it is insulated from the high voltage components.
- A ground fault monitor ❹\* continuously monitors for high voltage leakage to the metal chassis while the vehicle is running. If a malfunction is detected, the hybrid vehicle computer ❹\* will illuminate the master warning light  in the instrument cluster and a message indicating that the hybrid system is malfunctioning will be displayed on the multi-information display.
- The HV battery pack relays will automatically open to stop electricity flow in a collision sufficient to activate the SRS.

\*Numbers apply to the illustration on the following page.

## High Voltage Safety (Continued)

### Service Plug Grip

- The high voltage circuit is cut by removing the service plug grip (see page 15).

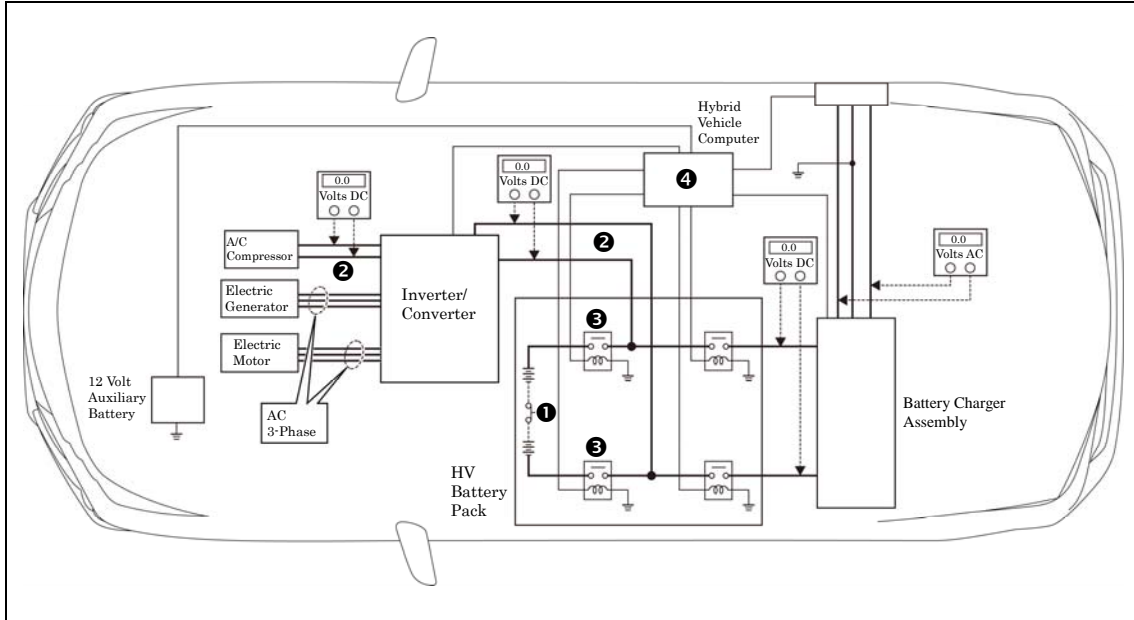

High Voltage Safety System – Vehicle Shut Off (READY-OFF)

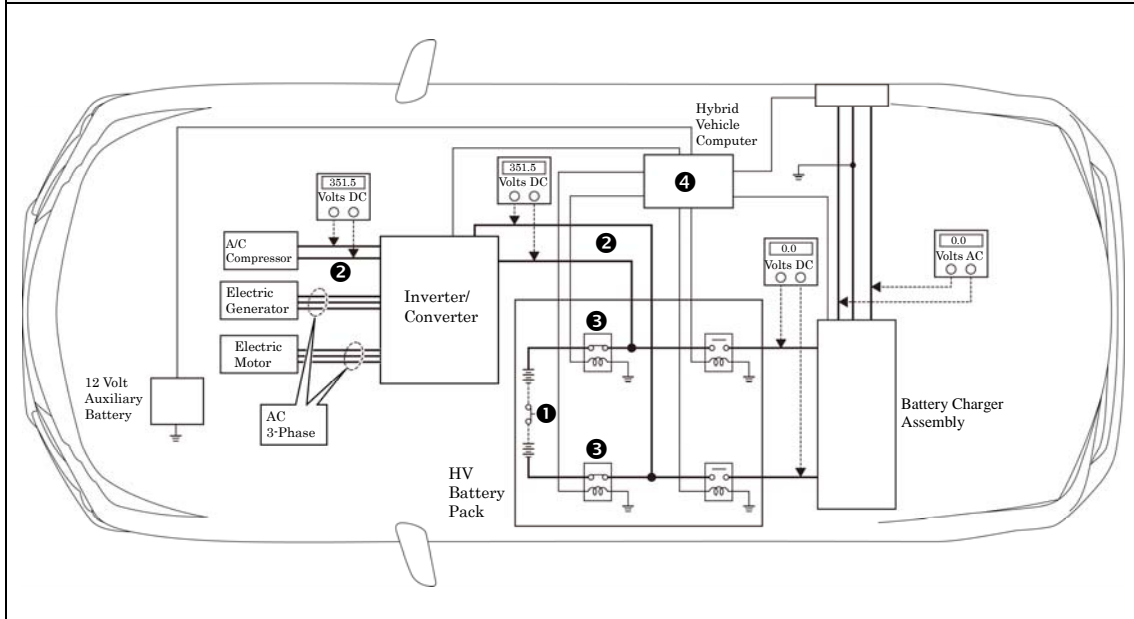

High Voltage Safety System – Vehicle On and Operational (READY-ON)



## Precaution to be observed when dismantling the vehicle



### **WARNING:**

- *The high voltage system may remain powered for up to 10 minutes after the vehicle is shut off or disabled. To prevent serious injury or death from severe burns or electric shock, avoid touching, cutting, or opening any orange high voltage power cable or high voltage component.*

### Necessary Items

- Protective clothing such as insulated gloves (electrically insulated), rubber gloves, safety goggles, and safety shoes.
- Insulating tape such as electrical tape that has a suitable electrical insulation rating.
- Before wearing insulated gloves, make sure that they are not cracked, ruptured, torn, or damaged in any way. Do not wear wet insulated gloves.
- An electrical tester that is capable of measuring DC 750 Volts or more.

## Spills

The PRIUS PRIME, PRIUS PHV contains the same common automotive fluids used in other non-hybrid Toyota vehicles, with the exception of the Li-ion electrolyte used in the HV battery pack. The electrolyte used in the Li-ion battery cells is a flammable organic electrolyte. The electrolyte is absorbed into the battery cell separators, even if the battery cells are crushed or cracked, it is unlikely that liquid electrolyte will leak. Any liquid electrolyte that leaks from a Li-ion battery cell quickly evaporates.



### **WARNING:**

- ***The Li-ion battery contains organic electrolyte. Only a small amount may leak from the batteries which may irritate the eyes, nose, throat, and skin.***
- ***Contact with the vapor produced by the electrolyte may irritate the nose and throat.***
- ***To avoid injury by coming in contact with the electrolyte or vapor, wear personal protective equipment for organic electrolyte including SCBA or protective mask for organic gases.***

- Handle Li-ion electrolyte spills using the following Personal Protective Equipment (PPE):
  - Splash shield or safety goggles. A fold down face shield is not acceptable for acid or electrolyte spills.
  - Rubber gloves or gloves suitable for organic solvents.
  - Apron suitable for organic solvents.
  - Rubber boots or boots suitable for organic solvents.
  - Protective mask for organic gases or SCBA.

## Dismantling the vehicle

The following 4 pages contain general instructions for use when working on a PRIUS PRIME, PRIUS PHV. Read these instructions before proceeding to the HV battery removal instructions on page 20.



### **WARNING:**

- **The high voltage system may remain powered for up to 10 minutes after the vehicle is shut off or disabled. To prevent serious injury or death from severe burns or electric shock, avoid touching, cutting, or opening any orange high voltage power cable or any high voltage component.**

1. Shut off the ignition (**READY** indicator is off).  
Then disconnect the cable from the auxiliary battery negative (-) terminal.

- (1) Loosen the nut, and disconnect the cable from the negative (-) auxiliary battery terminal.



2. Remove the rear No. 2 floor board.
3. Remove the rear No. 1 floor board.

- (1) Remove the 4 clips.
- (2) Disengage the 2 guides to remove the rear No. 1 floor board.

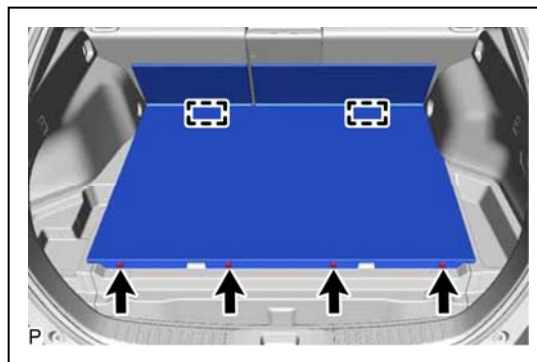

4. Remove the No. 4 HV battery shield panel.

- (1) Remove the 4 nuts and No. 4 HV battery shield panel from the HV battery.

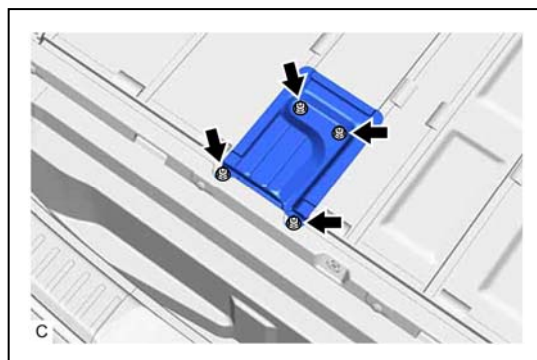

5. Remove the service plug grip.

**Caution:**

- **Wear insulated gloves.**
- **Do not inspect or service the high voltage system with the service plug grip installed.**



- **To reduce the risk of electric shock, make sure to remove the service plug grip to cut off the high voltage circuit before servicing the vehicle..**

- **To reduce the risk of electric shock, make sure to wait at least 10 minutes after removing the service plug grip to fully discharge the high voltage capacitor inside the inverter with converter assembly.**



- **Keep the removed service plug grip in your pocket to prevent other technicians from accidentally installing it while you are servicing the vehicle.**
- **Place a "HIGH VOLTAGE WORK IN PROGRESS. DO NOT TOUCH." sign, in order to prevent other technicians from accidentally reconnecting the power while work is in progress.**

**Notice:**

- After removing the service plug grip, turning the power switch on (READY) may cause a malfunction. Do not turn the power switch on (READY) unless instructed by the repair manual.
- Do not touch the terminals of the service plug grip.

**Hint:**

Waiting for at least 10 minutes is required to discharge the high voltage capacitor inside the inverter with converter assembly.

- (1) While wearing insulated gloves, rotate the handle of the service plug grip and remove the service plug grip as indicated by the arrows, in the order shown in the illustration.

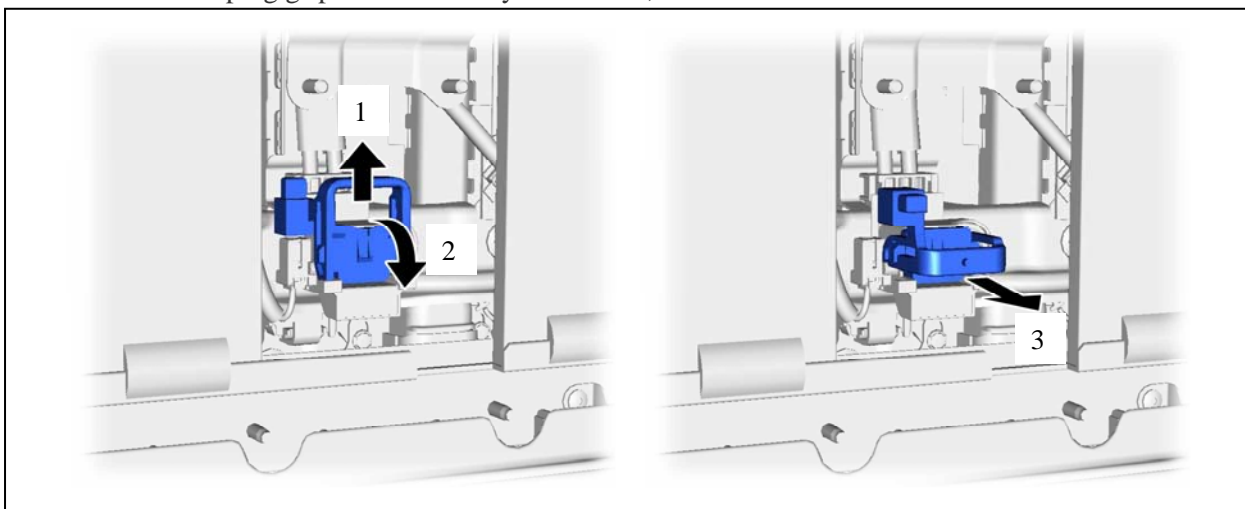

6. Carry the removed service plug grip in your pocket to prevent other staff from accidentally reinstalling it while you are dismantling the vehicle.
7. Make other staff aware that a high-voltage system is being dismantled by using the following sign: CAUTION: HIGH-VOLTAGE. DO NOT TOUCH (see page 19).
8. If the service plug grip cannot be removed due to damage to the vehicle, remove the **IG2-MAIN** fuse (25 A).

**Caution:**

**This operation shuts off the HV system. Be sure to wear insulated gloves because high voltage is not shut off inside the HV battery. When it is possible to remove the service plug grip, remove it and continue the procedure.**

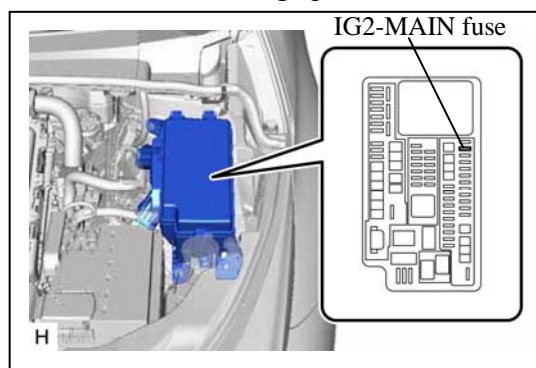

9. After disconnecting or exposing a high-voltage connector or terminal, insulate it immediately using insulating tape. Before disconnecting or touching a bare high-voltage terminal, wear insulated gloves.

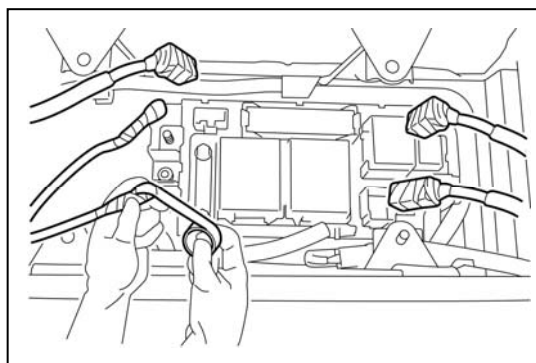

10. Check the HV battery and nearby area for leakage. If you find any liquid, it may be strong alkaline electrolyte. Wear rubber gloves and goggles and neutralize the liquid using a saturated boric acid solution or vinegar. Then wipe up the liquid using waste rags etc.

11. If the electrolyte comes into contact with your skin, wash the skin immediately using a saturated boric acid solution or a large amount of water. If the electrolyte adheres to any article of clothing, take the clothing off immediately.
12. If the electrolyte comes into contact with your eye(s), call out loudly for help. Do not rub your eye(s). Instead, wash the eye(s) with a dilute boric acid solution or a large amount of water and seek medical care.
13. With the exception of the HV battery, remove parts by following procedures which are similar to conventional Toyota vehicles. For the removal of the HV battery, refer to the following pages.

Person in charge: \_\_\_\_\_

**CAUTION:**  
**HIGH-VOLTAGE.**  
**DO NOT TOUCH.**

**CAUTION:**  
**HIGH-VOLTAGE.**  
**DO NOT TOUCH.**

Person in charge: \_\_\_\_\_

When performing work on the HV system, fold this sign and  
put it on the roof of the vehicle.

## Removal of HV battery



### **WARNING:**

- *Be sure to wear insulated gloves when handling high-voltage parts.*
- *Even if the vehicle is shut off and the relays are off, be sure to remove the service plug grip before performing any further work.*
- *Power remains in the high voltage electrical system for 10 minutes even after the HV battery pack is shut off because the circuit has a condenser that stores power.*
- *Make sure that the tester reading is 0 V before touching any high-voltage terminals which are not insulated.*
- *The SRS may remain powered for up to 90 seconds after the vehicle is shut off or disabled. To prevent serious injury or death from unintentional SRS deployment, avoid cutting the SRS components.*
- *The solar panels generate electricity with even a small amount of sunlight. To stop generation of electricity, cover the solar panels completely with a material that will block sunlight. (with Solar Charging System)*

1. SHUT OFF IGINATION (**READY** indicator is off)
2. REMOVE AUXILIARY BATTERY
  - (1) Loosen the nut and disconnect the cable from the negative (-) auxiliary battery terminal.





(2) Disengage the 2 claws and open the battery terminal.

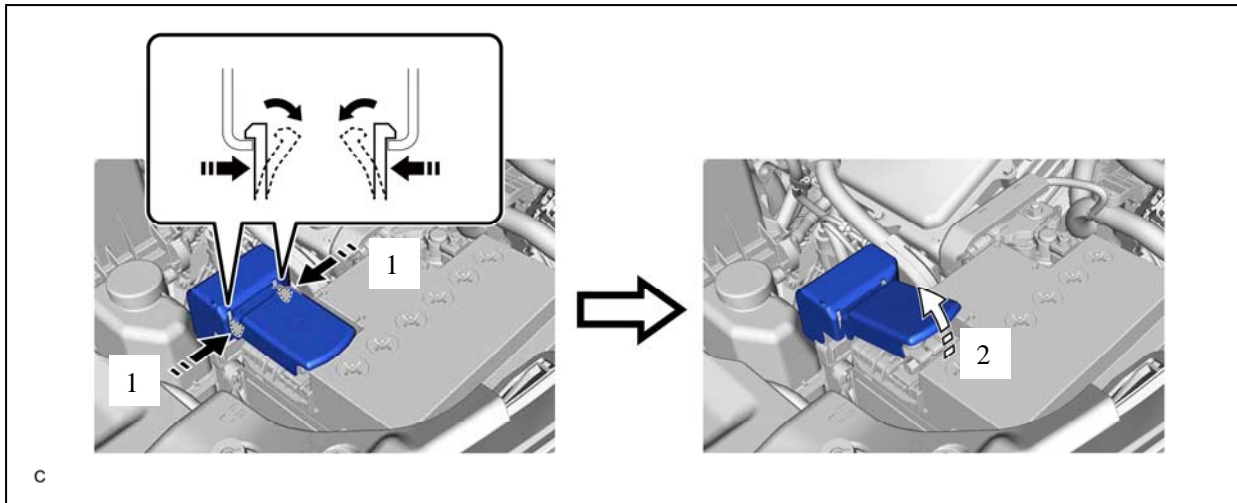

(3) Loosen the nut and disconnect the cable from the positive (+) auxiliary battery terminal.

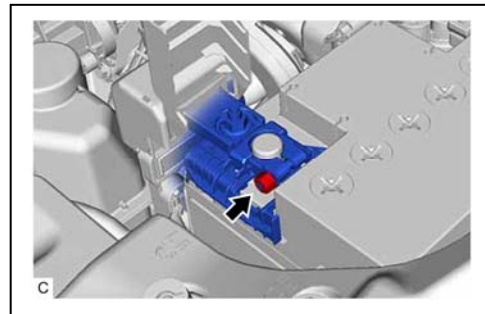

(4) Remove the bolt.



(5) Remove the No. 2 battery clamp as shown in the illustration.



(6) Remove the auxiliary battery.

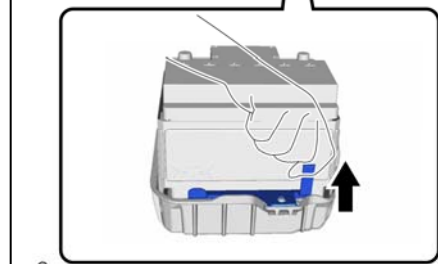

### 3. REMOVE REAR NO. 2 FLOOR BOARD

- (1) Remove the rear No. 2 floor board.

### 4. REMOVE REAR NO. 1 FLOOR BOARD

- (1) Remove the 4 clips.
- (2) Disengage the 2 guides to remove the rear No. 1 floor board.

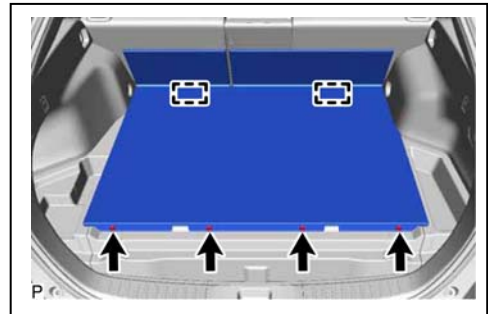

### 5. REMOVE NO. 4 HV BATTERY SHIELD PANEL

- (1) Remove the 4 nuts and No. 4 HV battery shield panel from the HV battery.

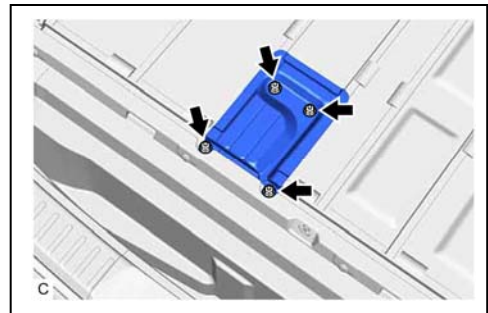

### 6. REMOVE SERVICE PLUG GRIP

#### Caution:

- **Wear insulated gloves.**
- **Do not inspect or service the high voltage system with the service plug grip installed.**
- **To reduce the risk of electric shock, make sure to remove the service plug grip to cut off the high voltage circuit before servicing the vehicle.**



- **To reduce the risk of electric shock, make sure to wait at least 10 minutes after removing the service plug grip to fully discharge the high voltage capacitor inside the inverter with converter assembly.**



- Keep the removed service plug grip in your pocket to prevent other technicians from accidentally installing it while you are servicing the vehicle.
- Place a "HIGH VOLTAGE WORK IN PROGRESS. DO NOT TOUCH." sign, in order to prevent other technicians from accidentally reconnecting the power while work is in progress.

**Notice:**

- After removing the service plug grip, turning the power switch on (READY) may cause a malfunction. Do not turn the power switch on (READY) unless instructed by the repair manual.
- Do not touch the terminals of the service plug grip.

**Hint:**

Waiting for at least 10 minutes is required to discharge the high voltage capacitor inside the inverter with converter assembly.

- (1) While wearing insulated gloves, rotate the handle of the service plug grip and remove the service plug grip as indicated by the arrows, in the order shown in the illustration.

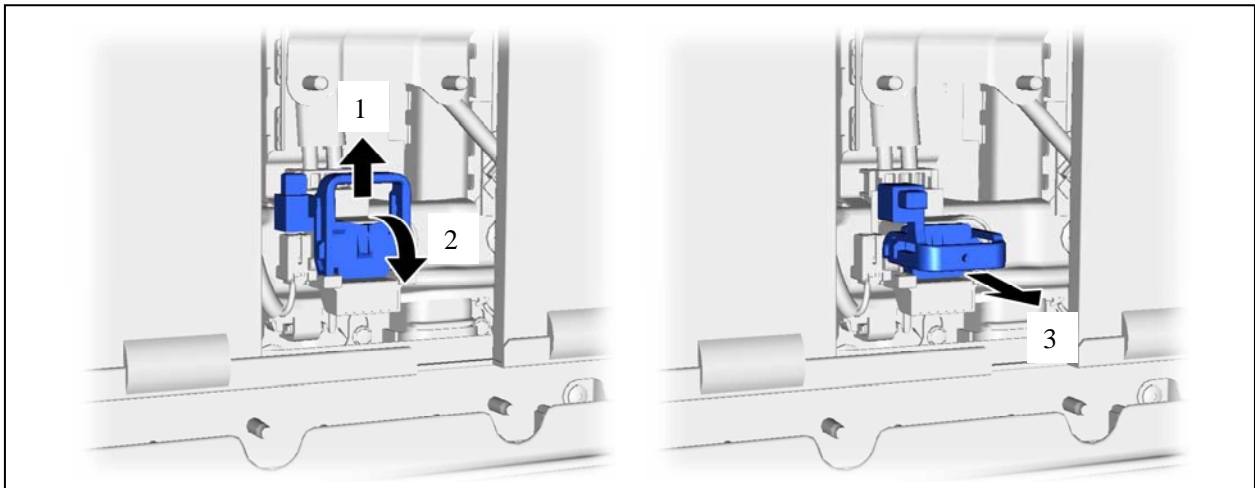

**7. REMOVE FRONT WIPER ARM HEAD CAP**

- (1) Using a screwdriver, disengage the 3 claws to remove the front wiper arm head cap.

**Hint:**

Use the same procedure for the RH side and LH side.

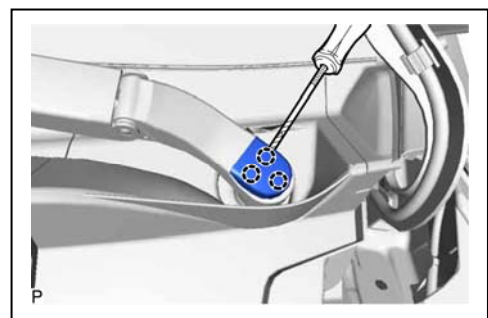

**8. REMOVE FRONT WIPER ARM AND BLADE ASSEMBLY LH**

- (1) Remove the nut and front wiper arm and blade assembly LH.

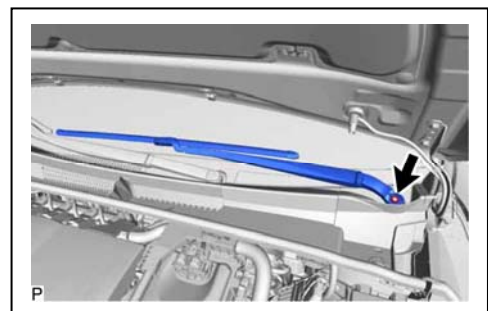

9. REMOVE FRONT WIPER ARM AND BLADE ASSEMBLY RH

- (1) Remove the nut and front wiper arm and blade assembly RH.

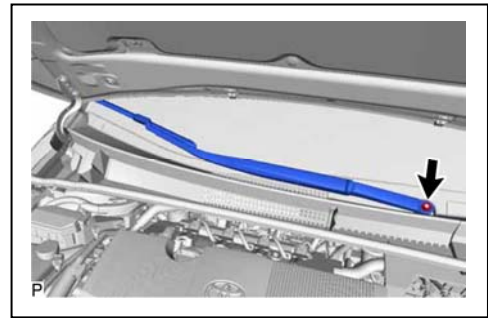

10. REMOVE COWL WATER EXTRACT SHIELD LH

- (1) Apply protective tape around the cowl water extract shield LH.

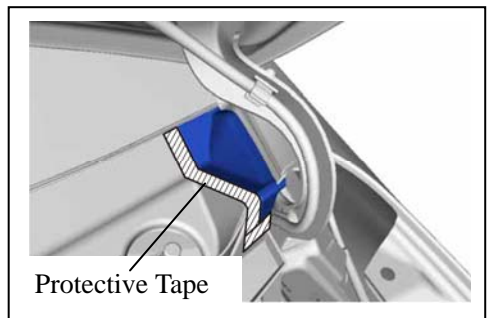

- (2) Using a moulding remover, disengage the claw as shown in the illustration.

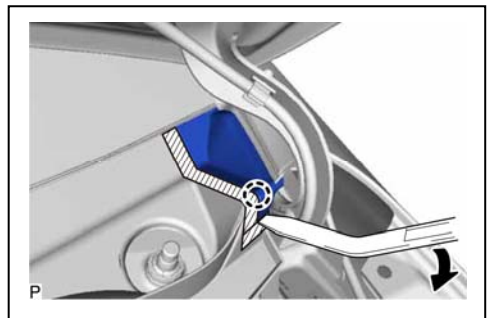

- (3) Using a moulding remover, disengage the cowl water extract shield LH from the windshield glass.

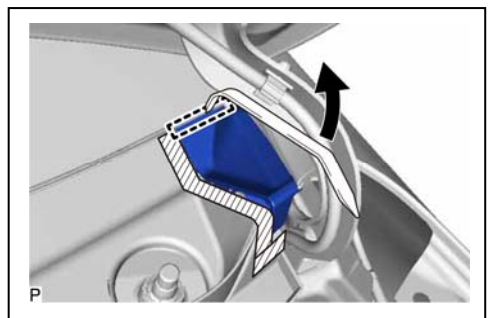

- (4) Disengage the claw and guide.

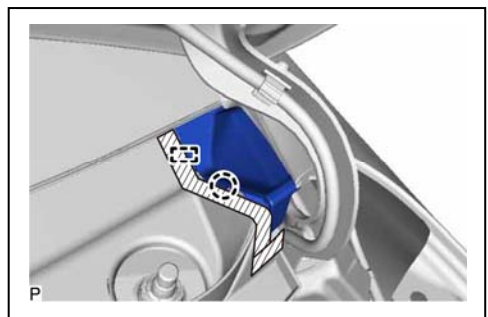

- (5) Remove the cowl water extract shield LH as shown in the illustration.

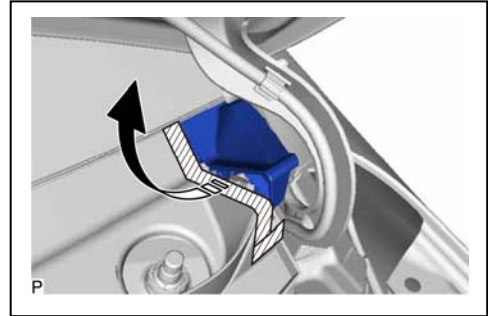

11. REMOVE COWL WATER EXTRACT SHIELD RH

Hint:

Use the same procedure as for the LH side.

12. REMOVE COWL TOP VENTILATOR LOUVER SUB-ASSEMBLY

- (1) Remove the 2 clips.

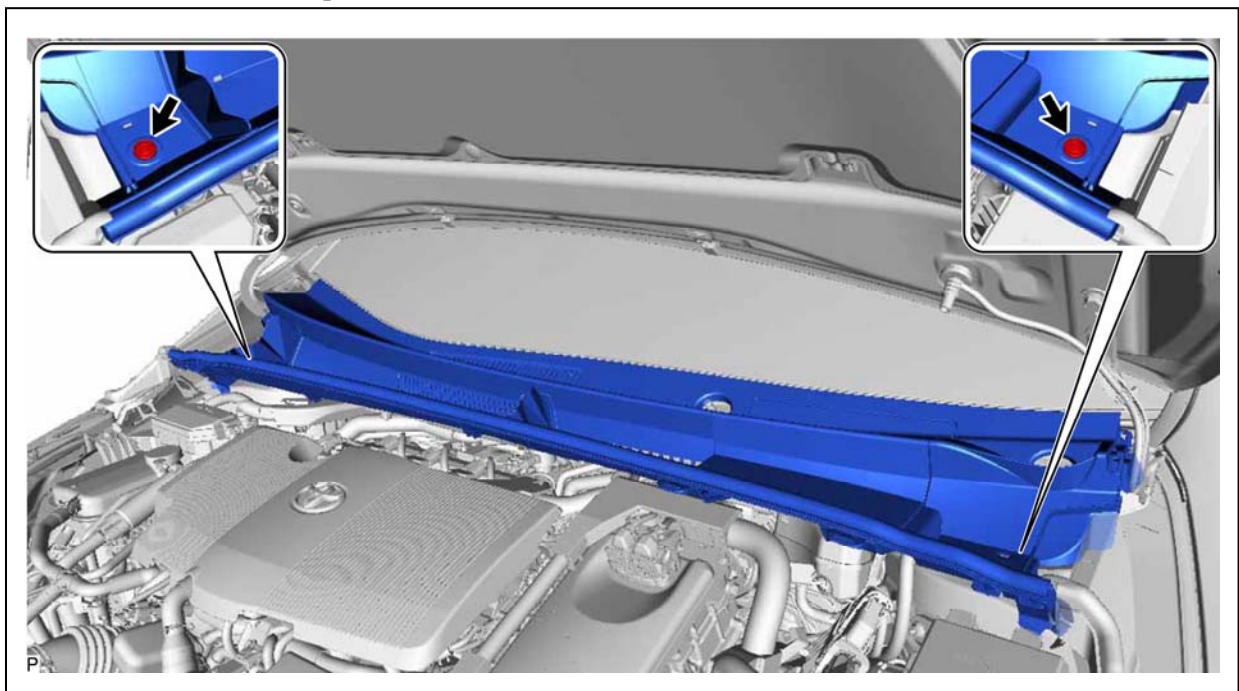

- (2) Close the hood sub-assembly.
- (3) Using a moulding remover, disengage the cowl top ventilator louver sub-assembly from the windshield glass as shown in the illustration.

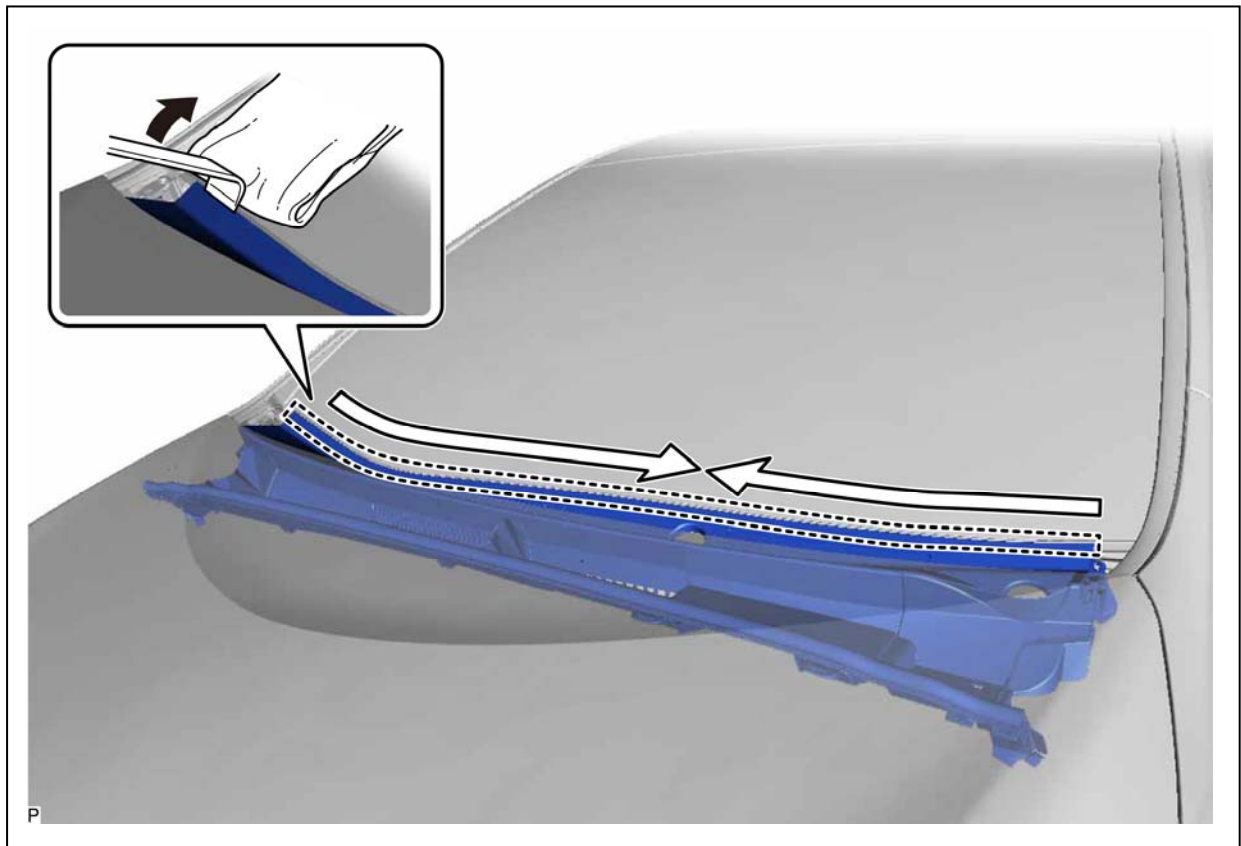

- (4) Open the hood sub-assembly.
- (5) Disengage the 3 guides and remove the cowl top ventilator louver sub-assembly as shown in the illustration.

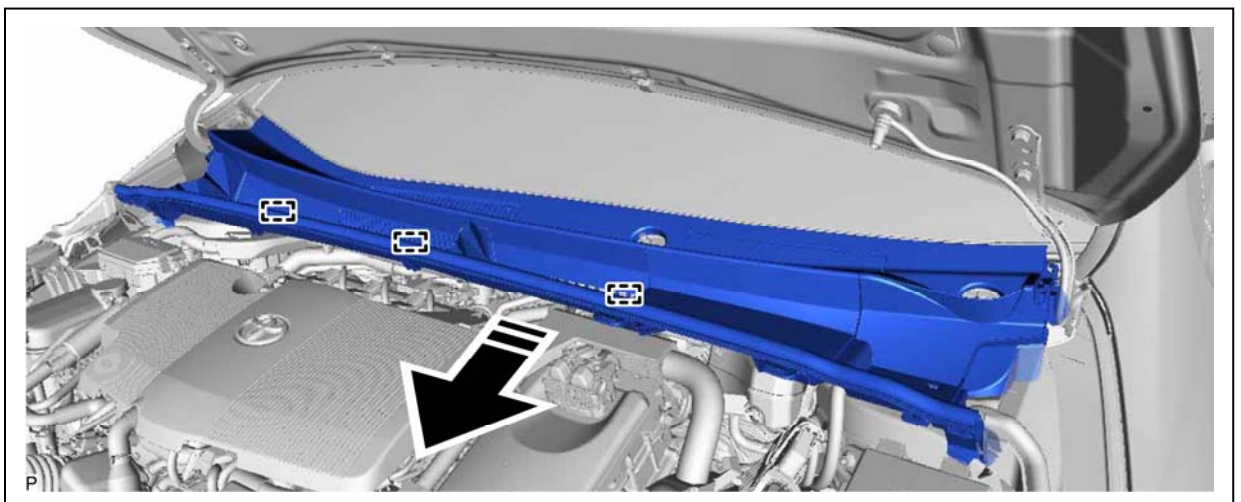

**Notice:**

When removing the cowl top ventilator louver sub-assembly, it may contact the brake master cylinder reservoir filler cap assembly and cause it to fall off. Check the installation condition of the brake master cylinder reservoir filler cap assembly after removing the cowl top ventilator louver sub-assembly.

### 13. REMOVE WINDSHIELD WIPER MOTOR AND LINK ASSEMBLY

- (1) Remove the 2 bolts.

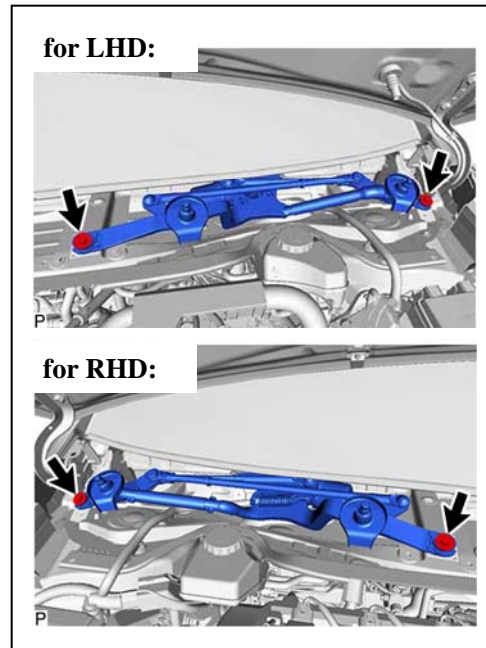

- (2) Disengage the motor grommet as shown in the illustration.

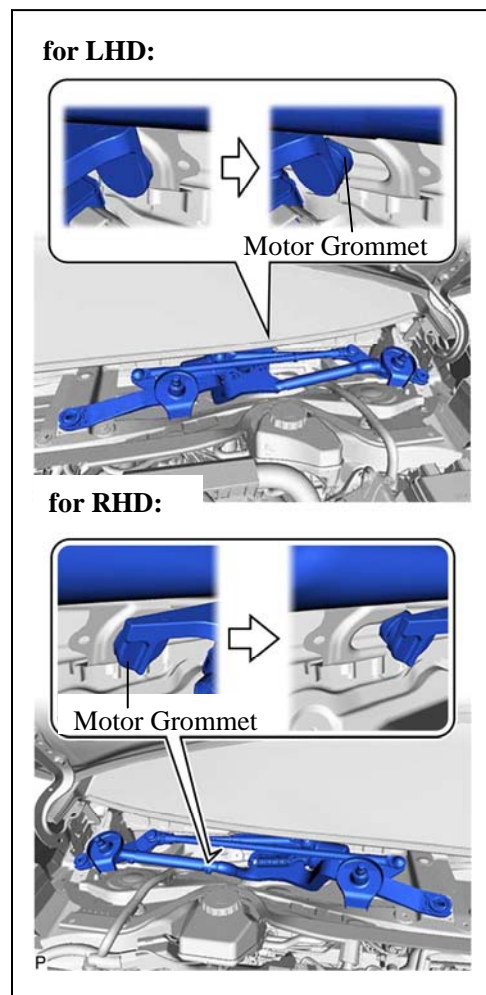

- (3) Disconnect the connector to remove the windshield wiper motor and link assembly.

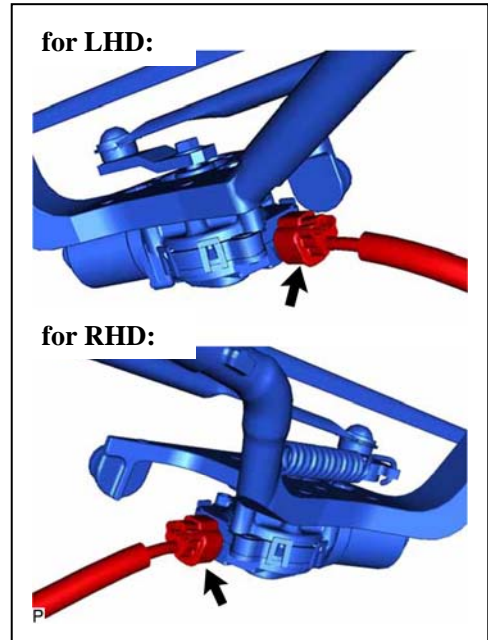

**14. REMOVE NO. 1 HEATER AIR DUCT SPLASH SHIELD SEAL (for LHD)**

- (1) Disengage the 2 claws and remove the No. 1 heater air duct splash shield seal from the outer cowl top panel sub-assembly.

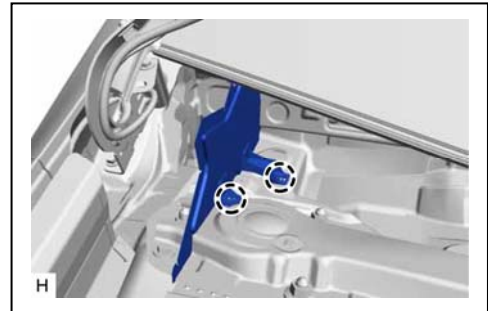

**15. REMOVE NO. 2 HEATER AIR DUCT SPLASH SHIELD SEAL (for RHD)**

- (1) Disengage the 2 claws and remove the No. 2 heater air duct splash shield seal from the outer cowl top panel sub-assembly.

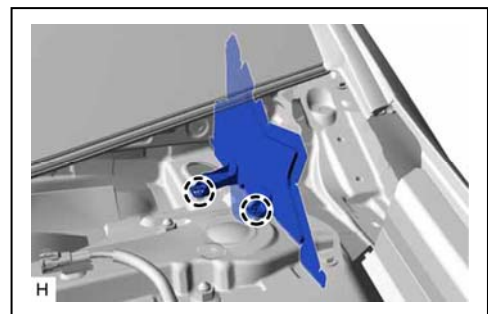

**16. REMOVE WATER GUARD PLATE**

- (1) Disengage the claw and remove the water guard plate.

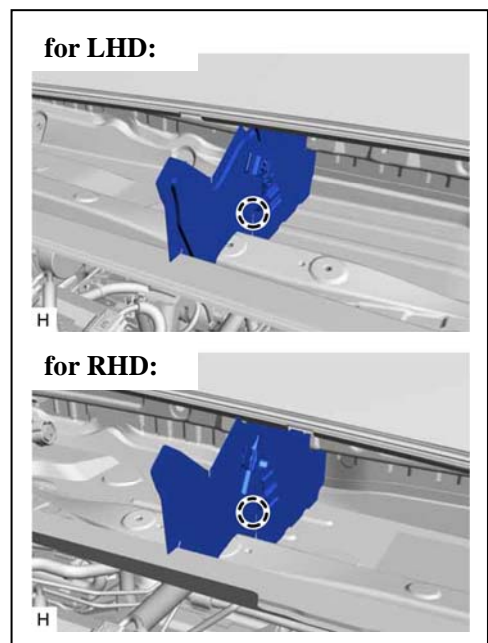



## 17. REMOVE COWL BODY MOUNTING REINFORCEMENT LH

- (1) Remove the 4 bolts and cowl body mounting reinforcement LH from the outer cowl top panel sub-assembly and vehicle body.

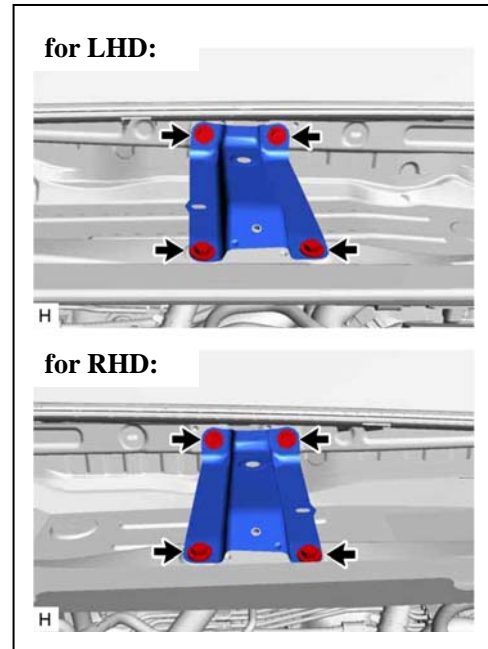

## 18. REMOVE OUTER COWL TOP PANEL SUB-ASSEMBLY

- (1) Disengage the 2 clamps and separate the wire harness from the outer cowl top panel sub-assembly.

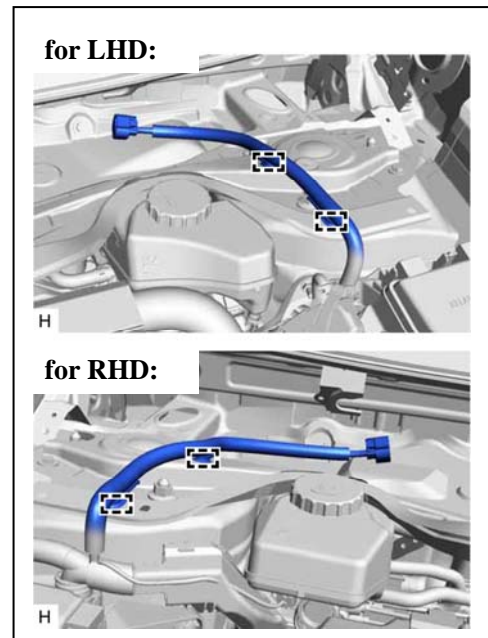

- (2) Remove the 7 bolts, 4 nuts and outer cowl top panel sub-assembly.

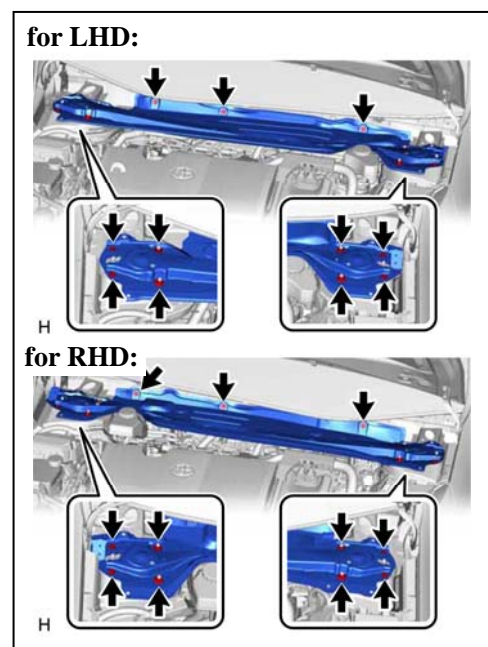

## 19. REMOVE NO. 1 ENGINE COVER SUB-ASSEMBLY

- (1) Disengage the 3 clips in the order shown in the illustration to remove the No. 1 engine cover sub-assembly.

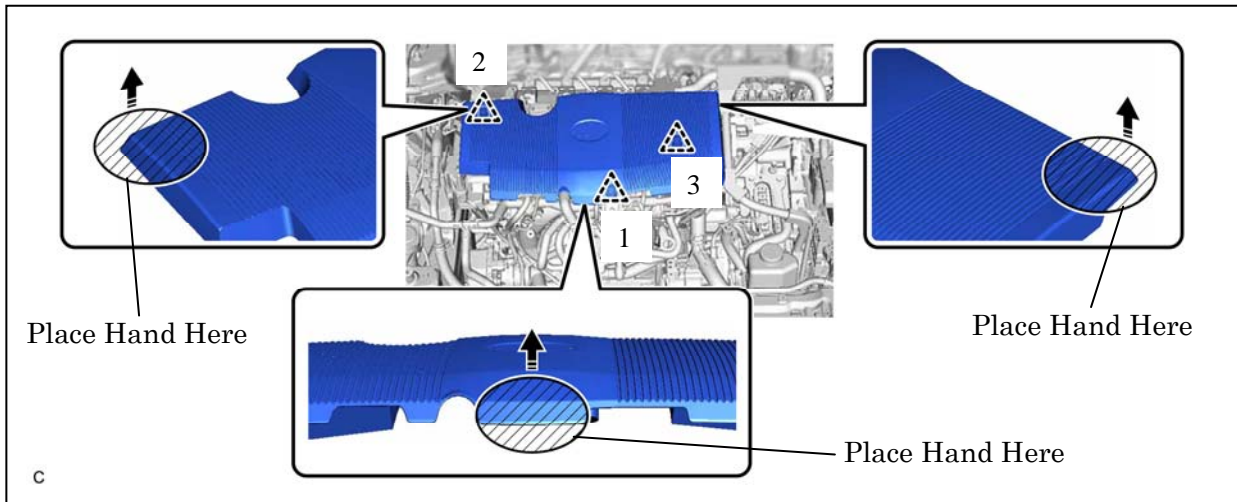

### Notice:

- Pull the No. 1 engine cover sub-assembly straight up to remove. Attempting to pull the No. 1 engine cover sub-assembly forward or attempting to pull it up by holding the left and right sides may cause the No. 1 engine cover sub-assembly to break.
- If the clips are not disengaged in the order shown in the illustration, the No. 1 engine cover sub-assembly may be damaged.

## 20. DISCONNECT ENGINE WIRE

(without Canister Pump Module)

### Caution:

**Wear insulated gloves.**

### Notice:

Do not allow any foreign matter or water to enter the inverter with converter assembly.

- (1) Move each lock lever as shown in the illustration and disconnect the 2 inverter with converter assembly connectors.

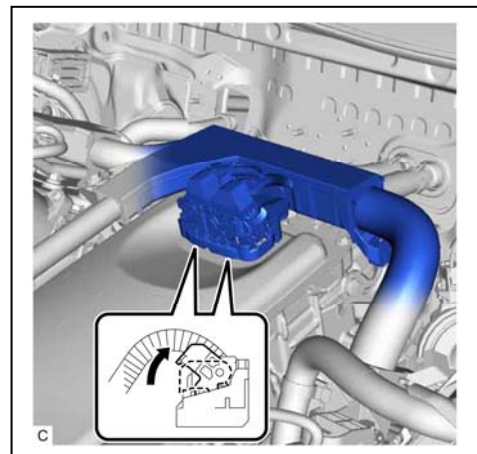

### Notice:

- Cover the hole where the cable was connected with tape (non-residue type) or equivalent to prevent entry of foreign matter.
- Insulate the disconnected terminals with insulating tape.

- (2) Remove the bolt.
- (3) Disengage the 2 clamps and disconnect the engine wire.

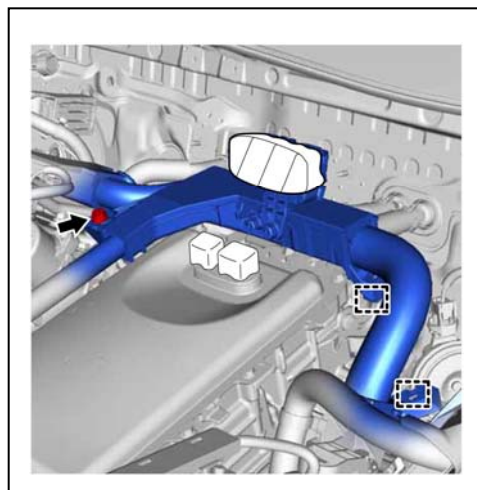

## 21. DISCONNECT ENGINE WIRE

(with Canister Pump Module)

**Caution:**

**Wear insulated gloves.**

**Notice:**

Do not allow any foreign matter or water to enter the inverter with converter assembly.

- (1) Move the lock lever as shown in the illustration and disconnect the inverter with converter assembly connector.

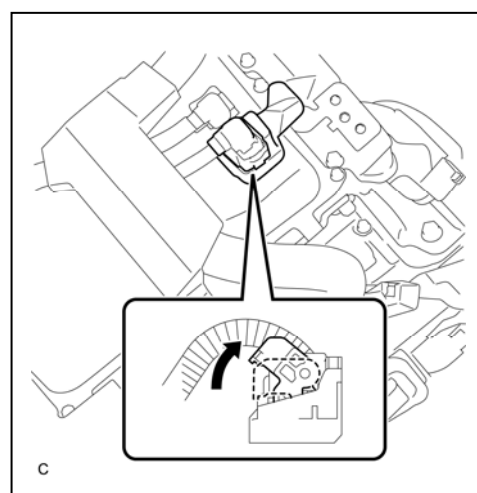

**Notice:**

- Cover the hole where the cable was connected with tape (non-residue type) or equivalent to prevent entry of foreign matter.
- Insulate the disconnected terminals with insulating tape.

## 22. REMOVE CONNECTOR COVER ASSEMBLY

**Caution:**

**Wear insulated gloves.**

- (1) Remove the bolt (B).
- (2) Using a T25 "TORX" socket wrench, remove the bolt (A) and connector cover assembly from the inverter with converter assembly.

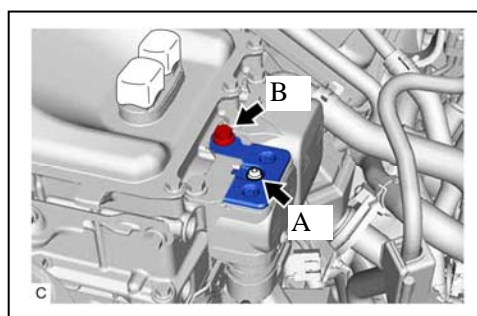

**Notice:**

Do not allow any foreign matter or water to enter the inverter with converter assembly.

23. CHECK TERMINAL VOLTAGE

**Caution:**

**Wear insulated gloves.**

**Notice:**

Do not allow any foreign matter or water to enter the inverter with converter assembly.

- (1) Using a voltmeter, measure the voltage between the terminals of the 2 phase connectors.

**Standard Voltage: 0 V**

**Hint:**

Use a measuring range of DC 750 V or more on the voltmeter.

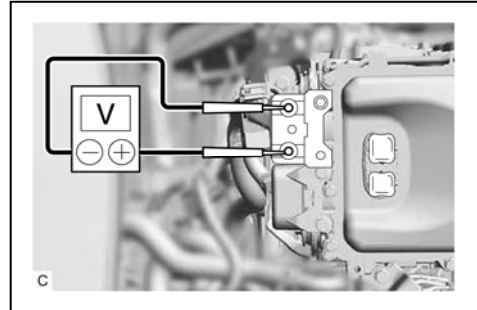

24. REMOVE REAR SEAT CUSHION ASSEMBLY LH (with Solar Charging System)

**Caution:**

**Wear protective gloves. Sharp areas on the seat frame may injure your hands.**

- (1) Lift the outer edge of the rear seat cushion assembly LH as shown in the illustration and disengage the rear seat cushion frame hook on the outer side of the rear seat cushion assembly LH from the rear seat cushion lock hook.

**Notice:**

Be sure to hold the parts of the seat cushion assembly directly next to the rear seat cushion frame hook when lifting it. Lifting a different part of the cushion may deform the rear seat cushion frame.

**Standard Measurement:**

Area	Measurement
A	93 mm (3.66 in.)
B	63 mm (2.48 in.)

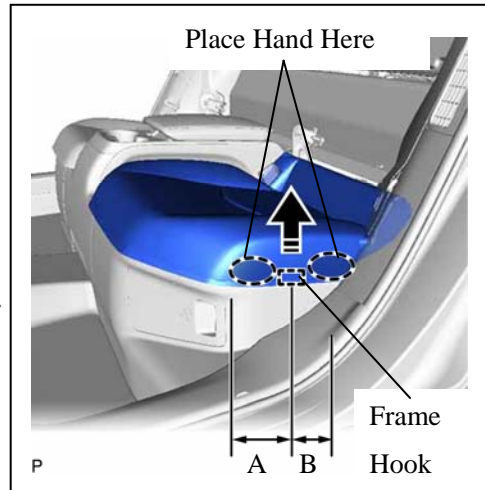

- (2) Lift the front edge of the rear seat cushion assembly LH as shown in the illustration and disengage the rear seat cushion frame hook on the front side of the rear seat cushion assembly LH from the rear seat cushion lock hook.

**Notice:**

Be sure to hold the parts of the seat cushion assembly directly next to the rear seat cushion frame hook when lifting it. Lifting a different part of the cushion may deform the rear seat cushion frame.

**Standard Measurement:**

Area	Measurement
A	135 mm (5.31 in.)

- (3) Disengage the rear seat cushion frame hook on the rear side of the rear seat cushion assembly as shown in the illustration and remove the rear seat cushion assembly LH.

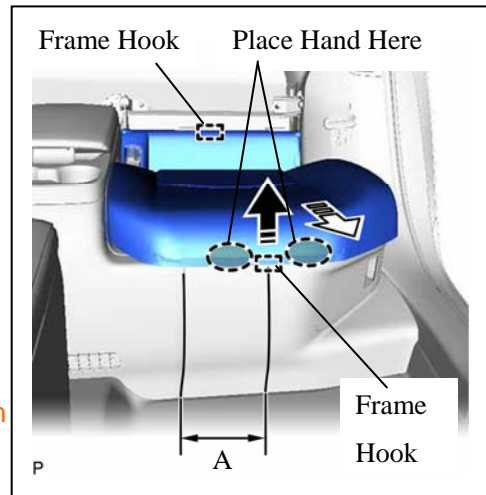

**25. REMOVE REAR SEAT CUSHION ASSEMBLY RH (with Solar Charging System)**

**Hint:**

Use the same procedure as for the LH side.

**26. REMOVE REAR SEAT CUSHION LOCK HOOK (with Solar Charging System)**

- (1) Disengage the 4 claws to remove the 2 rear seat cushion lock hooks as shown in the illustration.

**Hint:**

Use the same procedure for the RH side and LH side.

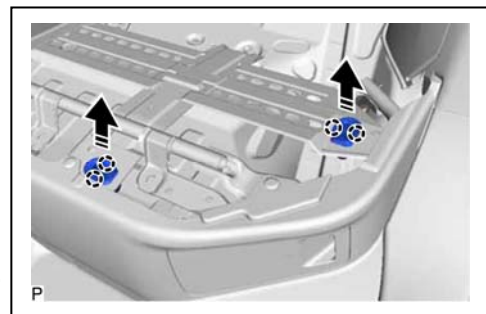

**27. REMOVE REAR DOOR SCUFF PLATE LH (with Solar Charging System)**

- (1) Disengage the claw as shown in the illustration.

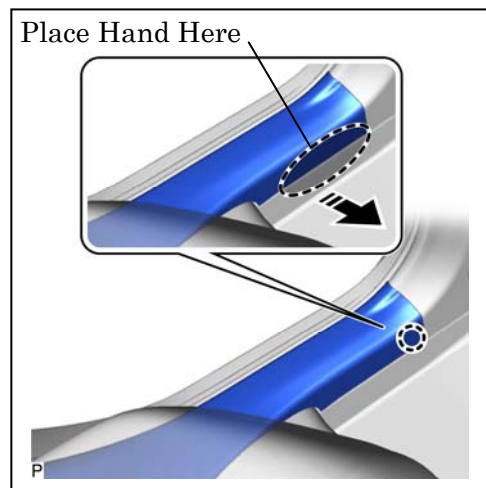

- (2) Disengage the 6 claws and 3 guides to remove the rear door scuff plate LH as shown in the illustration.

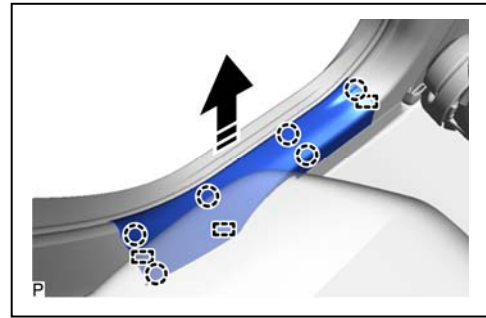

## 28. REMOVE REAR DOOR SCUFF PLATE RH (with Solar Charging System)

**Hint:**

Use the same procedure as for the LH side.

## 29. REMOVE REAR UNDER SIDE COVER LH (with Solar Charging System)

- (1) Remove the 2 clips.
- (2) Disengage the claw, 4 clips and guide to remove the rear under side cover LH as shown in the illustration.

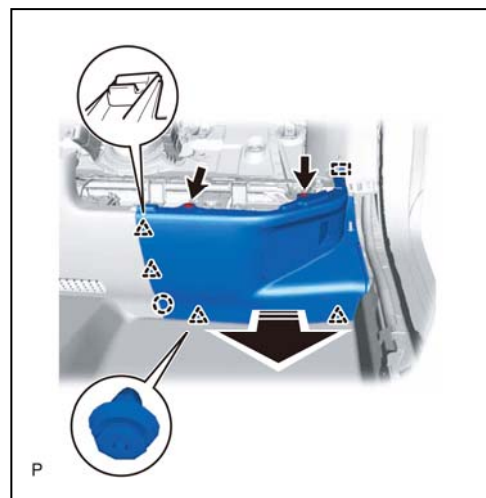

## 30. REMOVE REAR UNDER SIDE COVER RH (with Solar Charging System)

**Hint:**

Use the same procedure as for the LH side.

## 31. REMOVE REAR UNDER COVER (with Solar Charging System)

- (1) Disengage the claw and 2 clips as shown in the illustration.

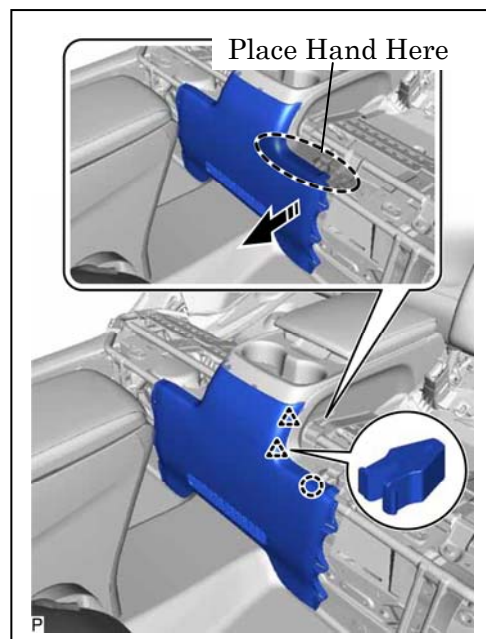

- (2) Disengage the claw and 3 clips as shown in the illustration.

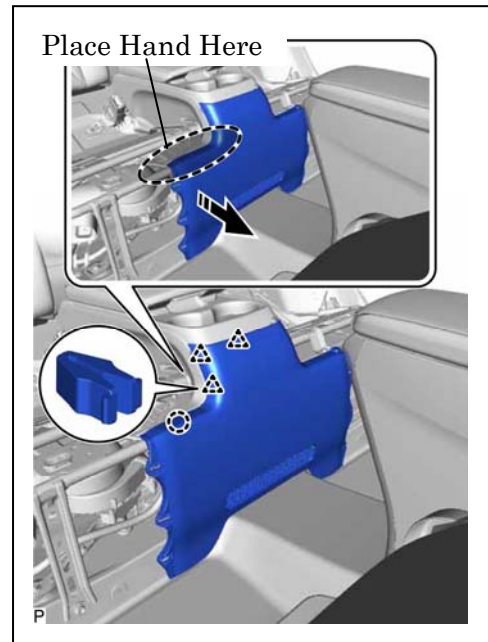

- (3) Disengage the 2 clips to remove the rear under cover as shown in the illustration.

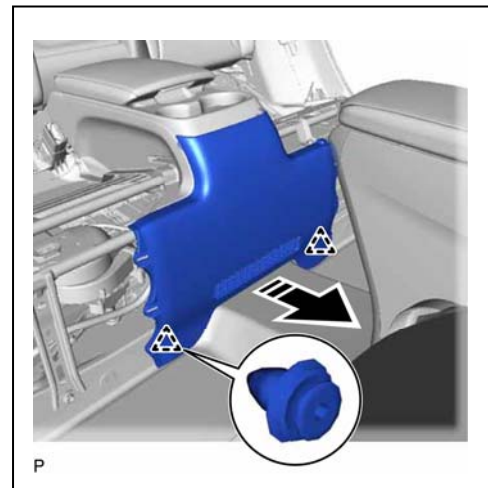

### 32. REMOVE REAR CONSOLE BOX COVER (with Solar Charging System)

- (1) Remove the rear console box cover.

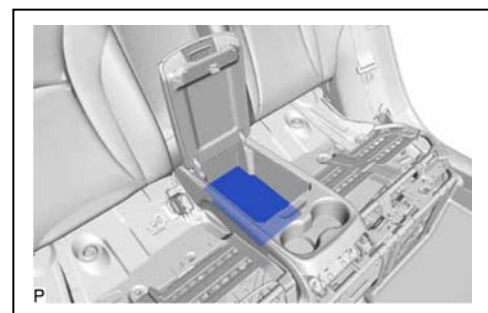

### 33. REMOVE REAR SEAT CONSOLE BOX ASSEMBLY (with Solar Charging System)

- (1) Remove the 4 bolts and rear seat console box Assembly.



34. DISCONNECT SOLAR ENERGY CONTROL UNIT CONNECTOR (with Solar Charging System)

**Caution:**

**Wear insulated gloves.**

**Notice:**

Insulate each disconnected connector with insulating tape. Wrap the connector from the wire harness side to the end of the connector.

- (1) Disconnect the 2 solar energy control unit connectors.
- (2) Disengage the clamp and remove the floor wire from the No. 2 solar energy control bracket.

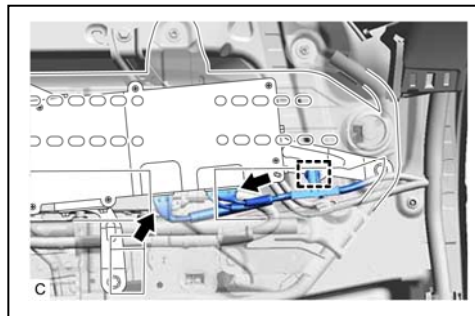

35. REMOVE TONNEAU COVER ASSEMBLY

- (1) Remove the tonneau cover assembly.

36. REMOVE REAR NO. 3 FLOOR BOARD

- (1) Remove the rear No. 3 floor board.

37. REMOVE REAR NO. 4 FLOOR BOARD

- (1) Remove the rear No. 4 floor board.

38. REMOVE DECK FLOOR BOX LH

- (1) Disengage the 2 claws and 5 guides to remove the deck floor box LH.

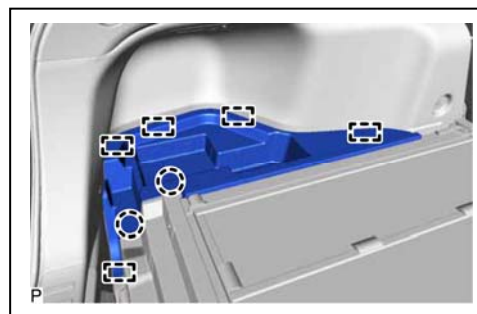

39. REMOVE DECK FLOOR BOX RH

- (1) Disengage the 2 claws and 4 guides to remove the deck floor box RH.

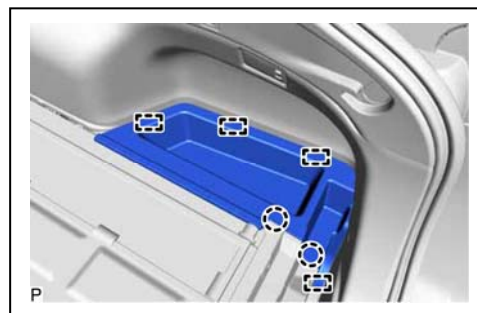

40. REMOVE DECK TRIM SERVICE HOLE COVER

- (1) Disengage the 4 claws to remove the deck trim service hole cover as shown in the illustration.

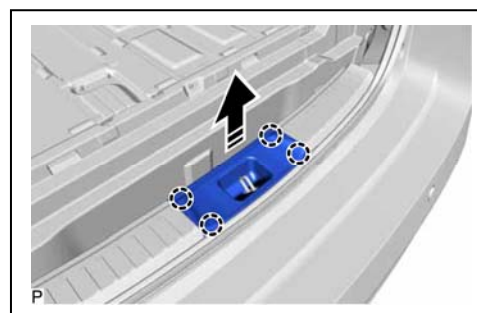



#### 41. REMOVE REAR DECK TRIM COVER

- (1) Remove the bolt.
- (2) Disengage the 4 clips to remove the rear deck trim cover.

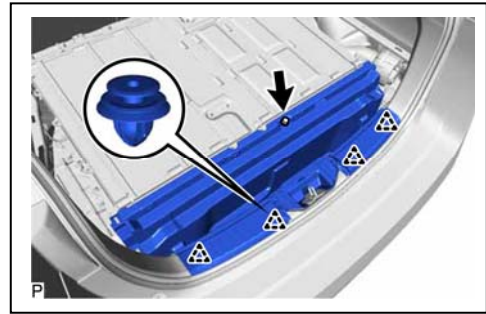

#### 42. REMOVE NO. 3 INDOOR ELECTRICAL KEY ANTENNA ASSEMBLY

- (1) Disconnect the connector.
- (2) Using a clip remover, disengage the clamp to remove the No. 3 indoor electrical key antenna assembly as shown in the illustration.

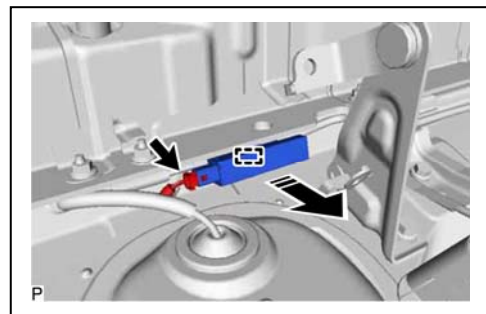

#### 43. DISCONNECT REAR DOOR OPENING TRIM WEATHERSTRIP LH

- (1) Disconnect the rear door opening trim weatherstrip LH.

#### 44. REMOVE REAR SEATBACK HINGE SUB-ASSEMBLY LH

- (1) Loosen the bolt to remove the rear seatback hinge sub-assembly LH.

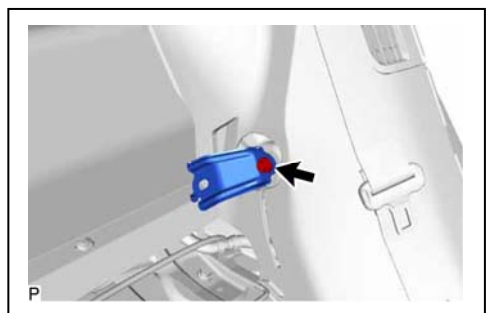

#### 45. REMOVE REAR SEAT SIDE GARNISH LH

- (1) Disengage the claw as shown in the illustration.

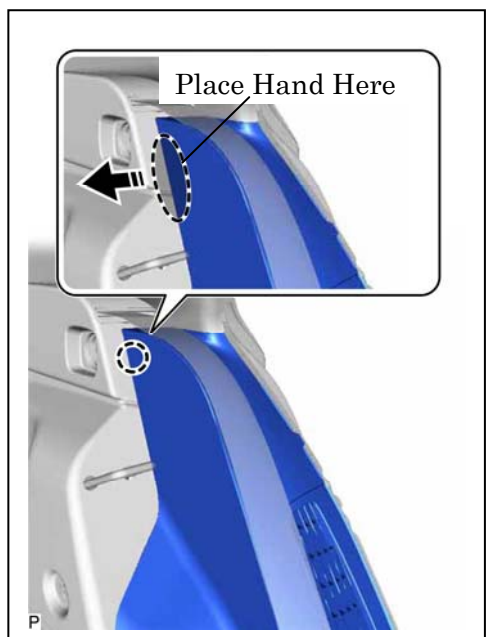

- (2) Disengage the 2 clips and 2 guides to remove the rear seat side garnish LH as shown in the illustration.

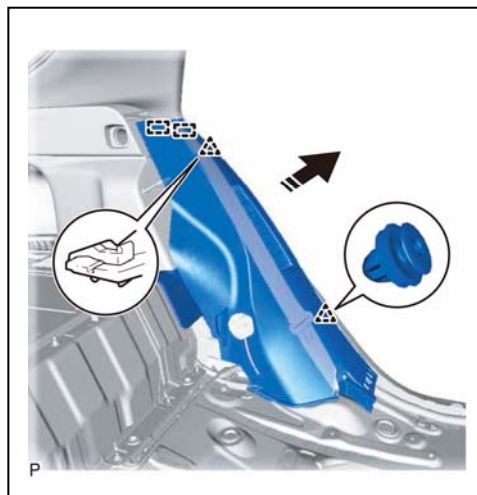

#### 46. DISCONNECT REAR DOOR OPENING TRIM WEATHERSTRIP RH

- (1) Disconnect the rear door opening trim weatherstrip RH.

#### 47. REMOVE REAR SEATBACK HINGE SUB-ASSEMBLY RH

Hint:

Use the same procedure as for the LH side.

#### 48. REMOVE REAR SEAT SIDE GARNISH RH

Hint:

Use the same procedure as for the LH side.

#### 49. REMOVE ROPE HOOK

(for RH Side without Garage Door Opener System  
or without Toyota Safety Sense)

- (1) Using a screwdriver, disengage the 2 claws and remove the rope hook as shown in the illustration.

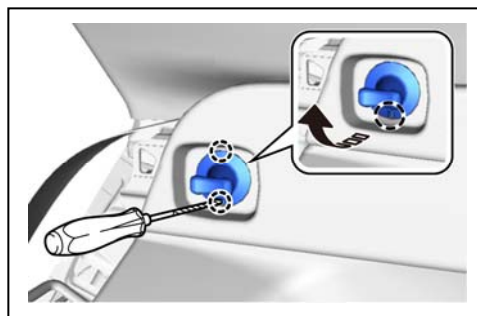

#### 50. REMOVE NO. 2 ROPE HOOK

(for RH Side without Garage Door Opener System  
or without Toyota Safety Sense)

- (1) Using a screwdriver, disengage the 2 claws to remove the No. 2 rope hook as shown in the illustration.

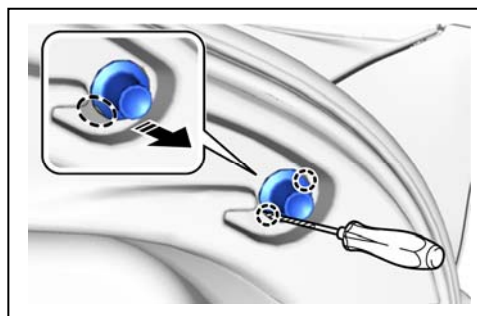

**51. REMOVE NO. 1 TONNEAU COVER HOLDER CAP**  
 (for RH Side with Garage Door Opener System  
 or with Toyota Safety Sense)

- (1) Using a screwdriver, disengage the 2 claws to remove the No. 1 tonneau cover holder cap as shown in the illustration.

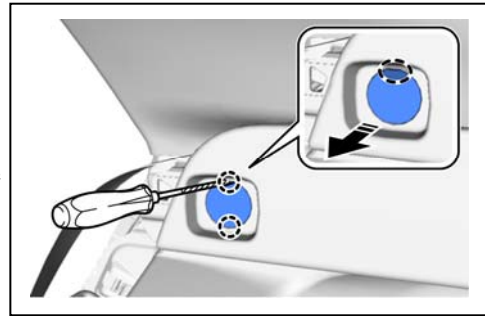

**52. REMOVE TONNEAU COVER HOOK A**  
 (for RH Side with Garage Door Opener System  
 or with Toyota Safety Sense)

- (1) Using a screwdriver, disengage the 2 claws to remove the tonneau cover hook A as shown in the illustration.

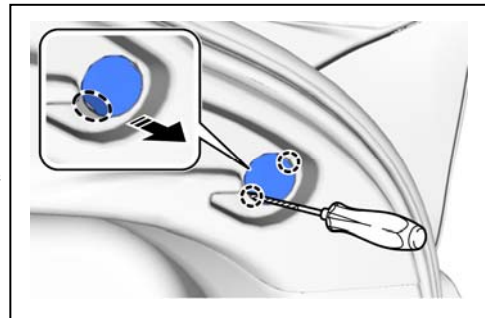

**53. REMOVE NO. 1 LUGGAGE COMPARTMENT LIGHT ASSEMBLY**

- (1) Using a moulding remover, disengage the claw.
- (2) Disconnect the connector to remove the No. 1 luggage compartment light assembly.

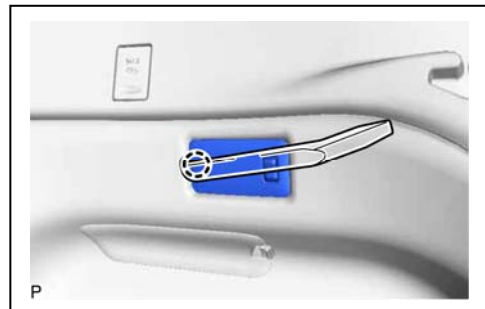

**54. REMOVE DECK TRIM SIDE PANEL ASSEMBLY RH**

- (1) Lower the No. 2 luggage compartment trim hook as shown in the illustration.

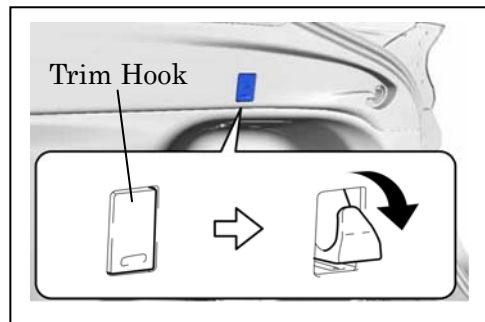

- (2) Disengage the clip as shown in the illustration.

**Hint:**

Insert the screwdriver into the hole (A).

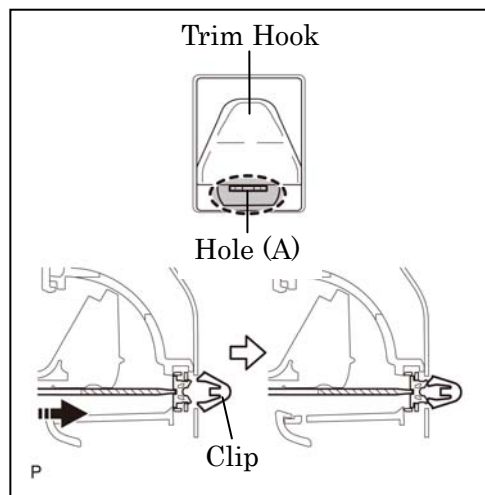

- (3) Remove the 2 screws.
- (4) Using a clip remover, remove the clip.

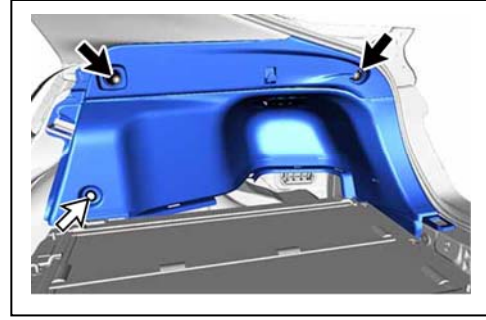

- (5) Disengage the 5 claws, 2 clips and guide to remove the deck trim side panel assembly RH as shown in the illustration.

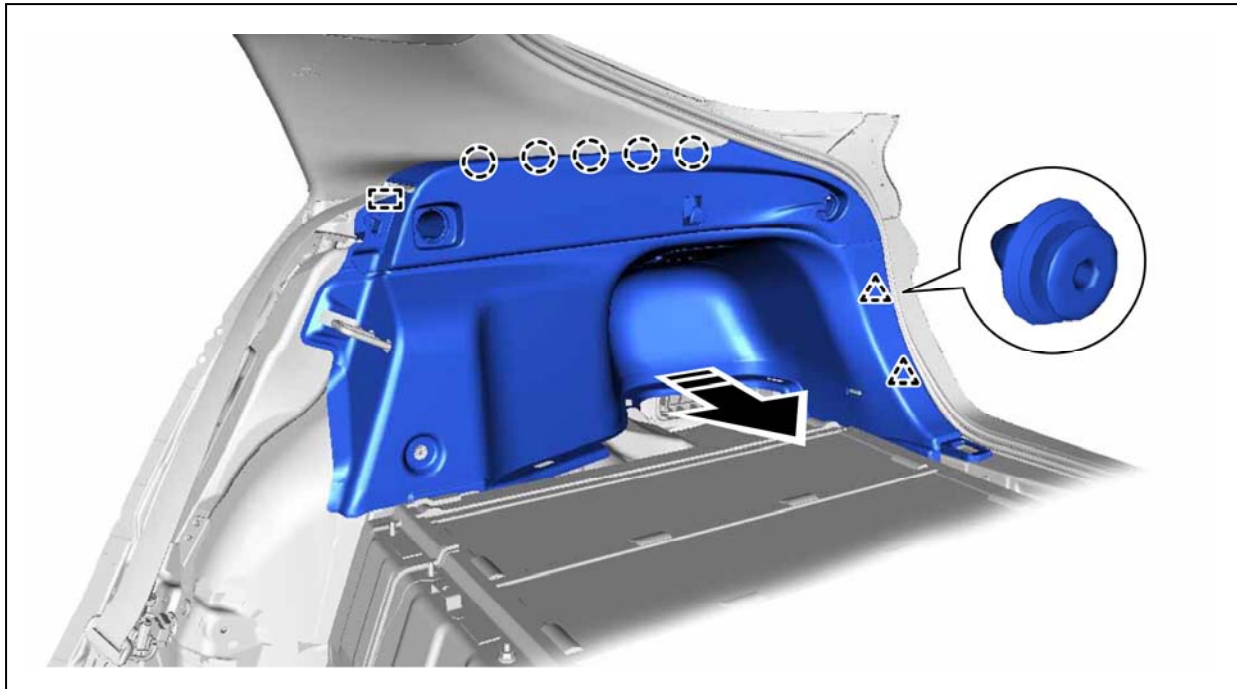

**55. REMOVE NO. 3 HYBRID BATTERY INTAKE DUCT (for LH Side)**

- (1) Remove the 3 clips and No. 3 hybrid battery intake duct.

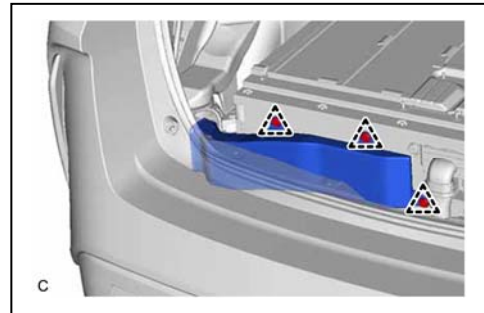

**56. REMOVE NO. 3 HYBRID BATTERY INTAKE DUCT (for RH Side)**

- (1) Remove the 3 clips and No. 3 hybrid battery intake duct.

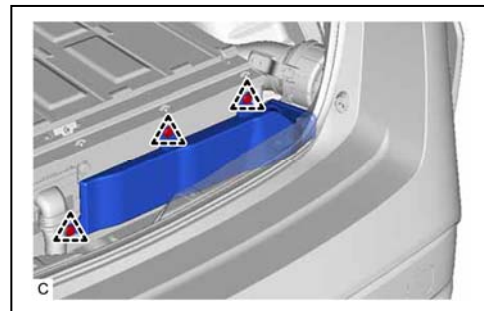

### 57. REMOVE HYBRID BATTERY HOSE ASSEMBLY

- (1) Disconnect the hybrid battery hose assembly from the vehicle.
- (2) Remove the 2 clips and hybrid battery hose assembly from the HV battery.

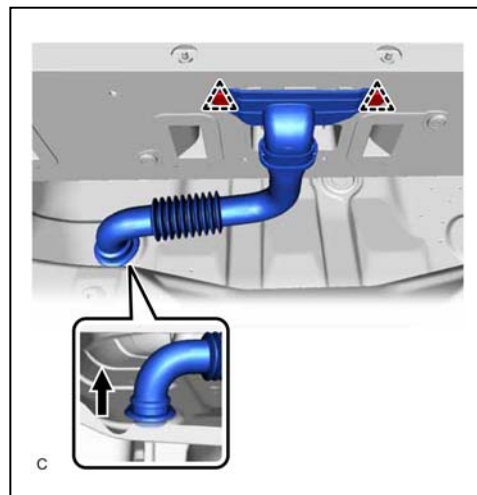

### 58. REMOVE NO. 1 HYBRID BATTERY INTAKE DUCT (for RH Side)

- (1) Remove the 2 clips and No. 1 hybrid battery intake duct.

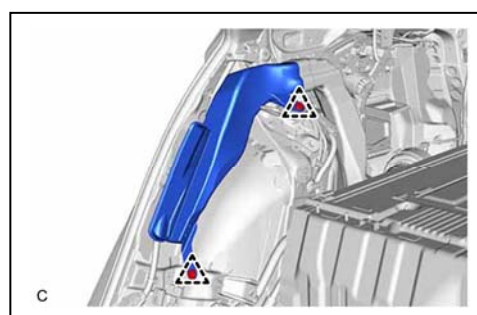

### 59. REMOVE NO. 2 HYBRID BATTERY INTAKE DUCT (for RH Side)

- (1) Remove the 2 clips and No. 2 hybrid battery intake duct.

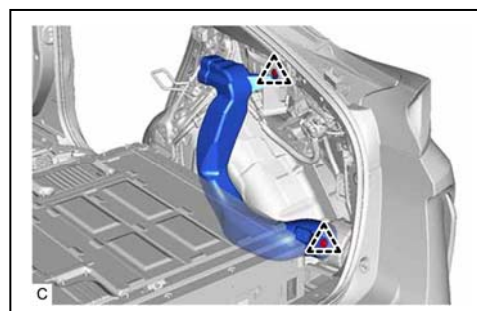

### 60. REMOVE CENTER REAR SEATBACK HINGE SUB-ASSEMBLY

- (1) Disconnect the rear seat inner belt assembly LH connector.
- (2) Disengage the clamp to disconnect the wire harness from the center rear seatback hinge subassembly.
- (3) Remove the 2 bolts and center rear seatback hinge sub-assembly from the vehicle body.

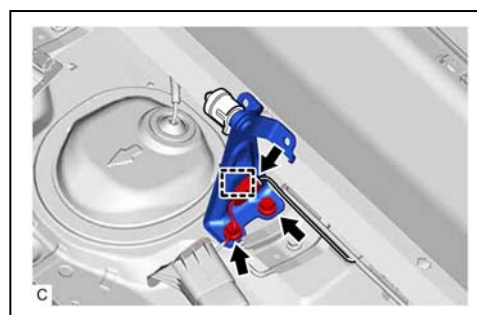

#### 61. REMOVE NO. 1 HV BATTERY SHIELD PANEL

**Caution:**

**Wear insulated gloves.**

- (1) Using the service plug grip, remove the battery cover lock striker.

**Hint:**

Insert the projection of the service plug grip and turn the button of the battery cover lock striker counterclockwise to release the lock.

- (2) Remove the 8 nuts and No. 1 HV battery shield panel from the HV battery.

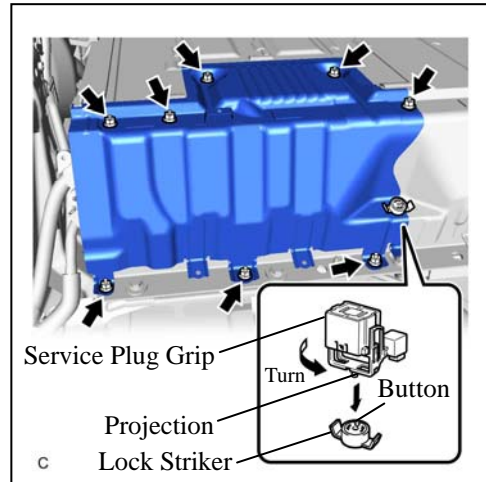

#### 62. REMOVE NO. 3 HV BATTERY SHIELD PANEL

**Caution:**

**Wear insulated gloves.**

- (1) Remove the 4 nuts and No. 3 HV battery shield panel from the HV battery.

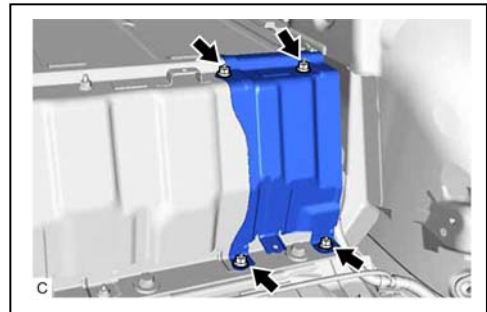

#### 63. REMOVE NO. 2 HV BATTERY SHIELD PANEL

**Caution:**

**Wear insulated gloves.**

- (1) Remove the 3 nuts and No. 2 HV battery shield panel from the HV battery.

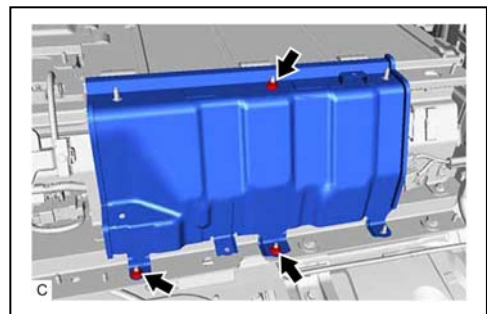

#### 64. DISCONNECT WIRE HARNESS

**Caution:**

**Wear insulated gloves.**

**Notice:**

Insulate each disconnected high-voltage connector with insulating tape. Wrap the connector from the wire harness side to the end of the connector.

- (1) Disconnect the 2 HV battery junction block assembly connectors (A).
- (2) Disconnect the 2 HV battery junction block assembly connectors (B).
- (3) Remove the 2 nuts and disconnect the earth terminals.
- (4) Remove the nut.
- (5) Disengage the 3 clamps.

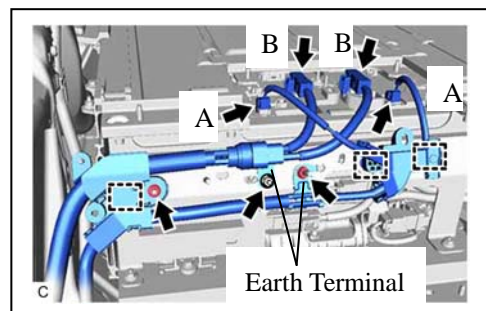

## 65. DISCONNECT FLOOR WIRE

### Caution:

### Wear insulated gloves.

- (1) Disengage the clamp.
- (2) Disconnect the 2 HV battery connectors.

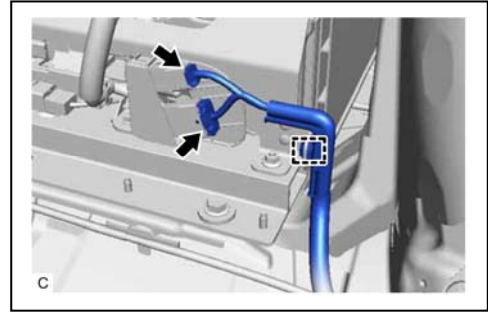

## 66. REMOVE HV BATTERY

### Caution:

### Wear insulated gloves.

- (1) Remove the 4 bolts (A) and 6 bolts (B).

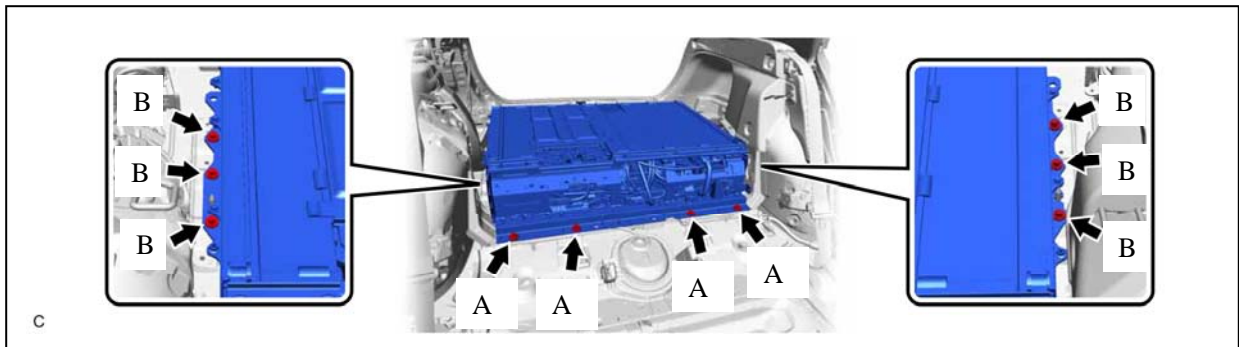

### Notice:

Do not allow foreign matter, such as grease or oil, to adhere to the bolts of the HV battery.

- (2) Set the 4 hooks and 2 straps as shown in the illustration.

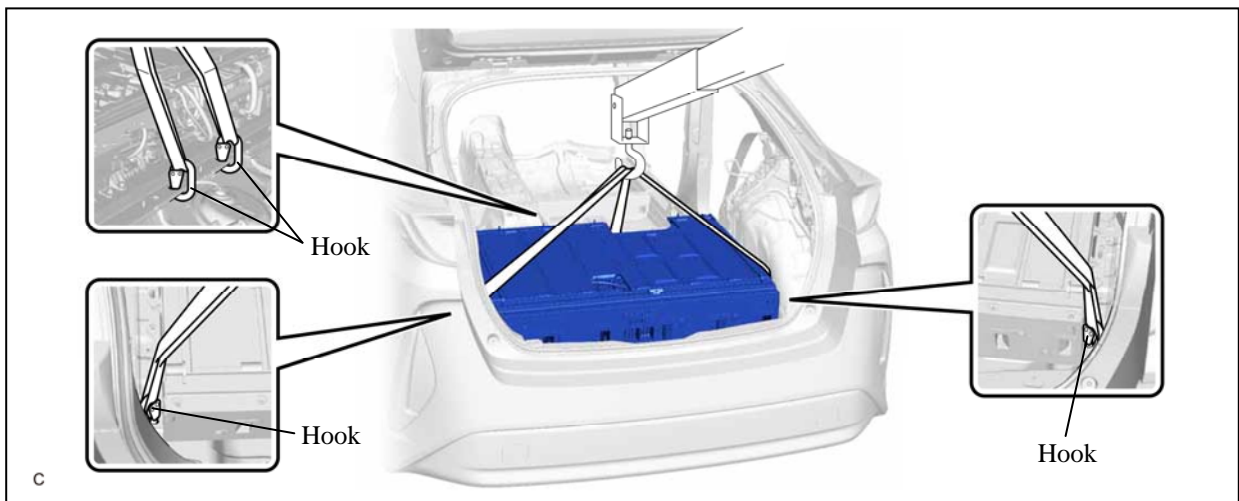

- (3) Using a suitable adaptor such as straps, remove the HV battery while tilting it.

### Notice:

- To prevent the wire harness from being caught, make sure to bundle the wire harness using insulating tape or equivalent.
- Since the HV battery is very heavy, 2 people are needed to remove it.
- When removing/ moving the HV battery, make sure not to tilt it more than 80°.
- Insulate the disconnected terminals or connectors with insulating tape.

- Make sure to insulate the high-voltage connectors and terminals of the HV battery with insulating tape after removing it. If the HV battery stored without insulating the connectors and terminals, electric shock or fire may result.
- Do not touch any high voltage wire harnesses, connectors or parts with bare hands.
- Do not put your hands into the openings of the HV battery.

