



RAV4 Hybrid

Gasoline-Electric

Hybrid Synergy Drive

HYBRID VEHICLE DISMANTLING MANUAL

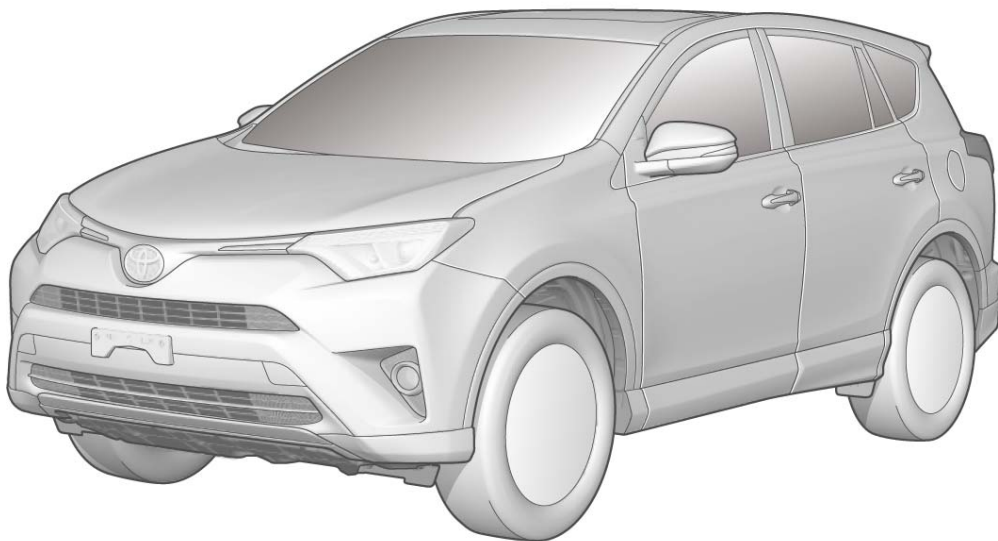

Foreword

This guide was developed to educate and assist dismantlers in the safe handling of Toyota RAV4 Hybrid gasoline-electric hybrid vehicles. RAV4 Hybrid dismantling procedures are similar to other non-hybrid Toyota vehicles with the exception of the high voltage electrical system. It is important to recognize and understand the high voltage electrical system features and specifications of the Toyota RAV4 Hybrid, as they may not be familiar to dismantlers.

High voltage electricity powers the A/C compressor, electric motors, generator, and inverter/converter. All other conventional automotive electrical devices such as the head lights, radio, and gauges are powered from a separate 12 V auxiliary battery. Numerous safeguards have been designed into the RAV4 Hybrid to help ensure the high voltage, approximately 244.8 V, Nickel Metal Hydride (NiMH) Hybrid Vehicle (HV) battery pack is kept safe and secure in an accident.

The NiMH HV battery pack contains sealed batteries that are similar to rechargeable batteries used in some battery operated power tools and other consumer products. The electrolyte is absorbed in the cell plates and will not normally leak out even if the battery is cracked. In the unlikely event the electrolyte does leak, it can be easily neutralized with a dilute boric acid solution or vinegar.

High voltage cables, identifiable by orange insulation and connectors, are isolated from the metal chassis of the vehicle.

Additional topics contained in the guide include:

- Toyota RAV4 Hybrid identification.
- Major hybrid component locations and descriptions.

By following the information in this guide, dismantlers will be able to handle RAV4 Hybrid hybrid-electric vehicles as safely as the dismantling of a conventional gasoline engine automobile.

© 2015 Toyota Motor Corporation

All rights reserved. This book may not be reproduced or copied, in whole or in part, without the written permission of Toyota Motor Corporation.

Table of Contents

<u>About the RAV4 Hybrid</u>	<u>1</u>
<u>RAV4 Hybrid Identification</u>	<u>2</u>
<u>RAV4 Hybrid Identification (Continued)</u>	<u>3</u>
<u>Exterior</u>	<u>3</u>
<u>Interior</u>	<u>4</u>
<u>Engine Compartment</u>	<u>5</u>
<u>Hybrid Component Locations & Descriptions</u>	<u>6</u>
<u>Hybrid Component Locations & Descriptions (Continued)</u>	<u>7</u>
<u>Specifications</u>	<u>7</u>
<u>Hybrid Synergy Drive Operation</u>	<u>8</u>
<u>Vehicle Operation</u>	<u>8</u>
<u>Hybrid Vehicle (HV) Battery Pack and Auxiliary Battery</u>	<u>9</u>
<u>HV Battery Pack</u>	<u>9</u>
<u>Components Powered by the HV Battery Pack</u>	<u>9</u>
<u>Hybrid Vehicle (HV) Battery Pack and Auxiliary Battery (Continued)</u>	<u>10</u>
<u>HV Battery Pack Recycling</u>	<u>10</u>
<u>Auxiliary Battery</u>	<u>10</u>
<u>High Voltage Safety</u>	<u>11</u>
<u>High Voltage Safety System</u>	<u>11</u>
<u>High Voltage Safety (Continued)</u>	<u>12</u>
<u>Service Plug Grip</u>	<u>12</u>
<u>Precaution to be observed when dismantling the vehicle</u>	<u>13</u>
<u>Necessary Items</u>	<u>13</u>
<u>Spills</u>	<u>14</u>
<u>Dismantling the vehicle</u>	<u>15</u>
<u>Removal of HV battery</u>	<u>20</u>

About the RAV4 Hybrid

The RAV4 Hybrid 5-door wagon joins the hybrid model for Toyota. Hybrid Synergy Drive means that the vehicle contains a gasoline engine and two electric motors for power.

The two hybrid power sources are stored on board the vehicle:

1. Gasoline stored in the fuel tank for the gasoline engine.
2. Electricity stored in a high voltage Hybrid Vehicle (HV) battery pack for the electric motors.

The result of combining these two power sources is improved fuel economy and reduced emissions. The gasoline engine also powers an electric generator to recharge the battery pack; unlike a pure all electric vehicle, the RAV4 Hybrid never needs to be recharged from an external electric power source.

Depending on the driving conditions one or both sources are used to power the vehicle. The following illustration demonstrates how the RAV4 Hybrid operates in various driving modes.

- ❶ During light acceleration at low speeds, the vehicle is powered by the electric motors. The gasoline engine is shut off.
- ❷ During normal driving, the vehicle is powered mainly by the gasoline engine. The gasoline engine also powers the generator to recharge the battery pack and to drive the motors.
- ❸ During full acceleration, such as climbing a hill, both the gasoline engine and the electric motors power the vehicle.
- ❹ During deceleration, such as when braking, the vehicle regenerates the kinetic energy from the front and rear wheels to produce electricity that recharges the battery pack.
- ❺ While the vehicle is stopped, the gasoline engine and electric motors are off, however the vehicle remains on and operational.

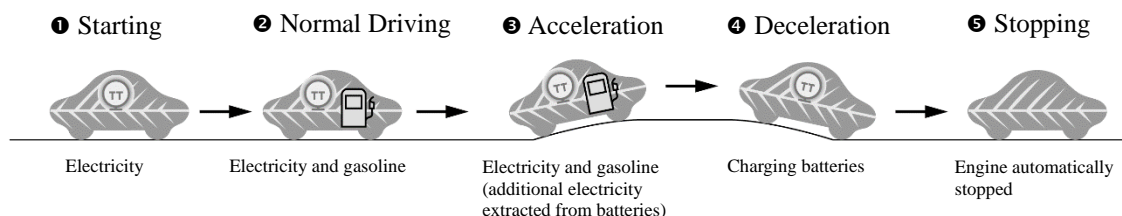

RAV4 Hybrid Identification

In appearance, the 2016 model year / 2015 calendar year RAV4 Hybrid is nearly identical to the conventional, non-hybrid Toyota RAV4. The RAV4 Hybrid is a 5-door wagon. Exterior, interior, and engine compartment illustrations are provided to assist in identification.

The alphanumeric 15 character Vehicle Identification Number (VIN) is provided on the left side windshield cowl, floor under the right side front seat and left side B pillar.

Example VIN:

<u>JTMRJREV5000101</u>	<u>JTMWR3EV5000101</u>
<u>JTMDJREV5000101</u>	<u>JTMRJREV5000101</u>
<u>JTMRJ3EV5000101</u>	<u>JTMDJREV5000101</u>
<u>JTMDJ3EV5000101</u>	<u>JTMWRREV5000101</u>
<u>JTMWR3EV5000101</u>	<u>JTMWRREV5000101</u>

A RAV4 Hybrid is identified by the first 8 alphanumeric characters.

JTMRJREV	JTMWR3EV
JTMDJREV	JTMRJREV
JTMRJ3EV	JTMDJREV
JTMDJ3EV	JTMWRREV
JTMWR3EV	JTMWRREV

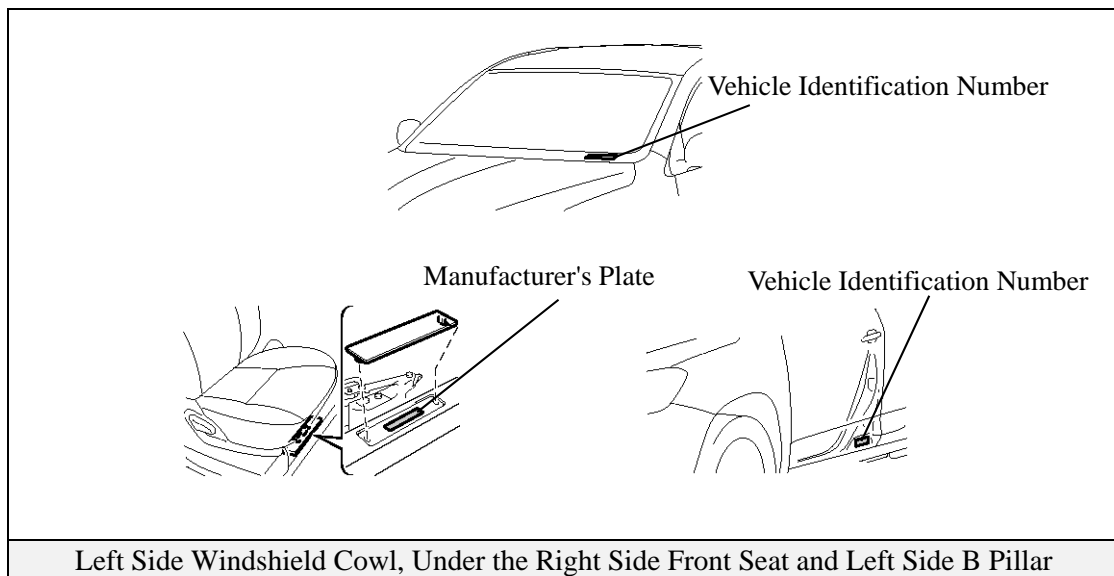

RAV4 Hybrid Identification (Continued)

Exterior

- ➊ **HYBRID** logos on the back door and each front fender.
- ➋ Gasoline fuel filler door located on left side rear quarter panel.

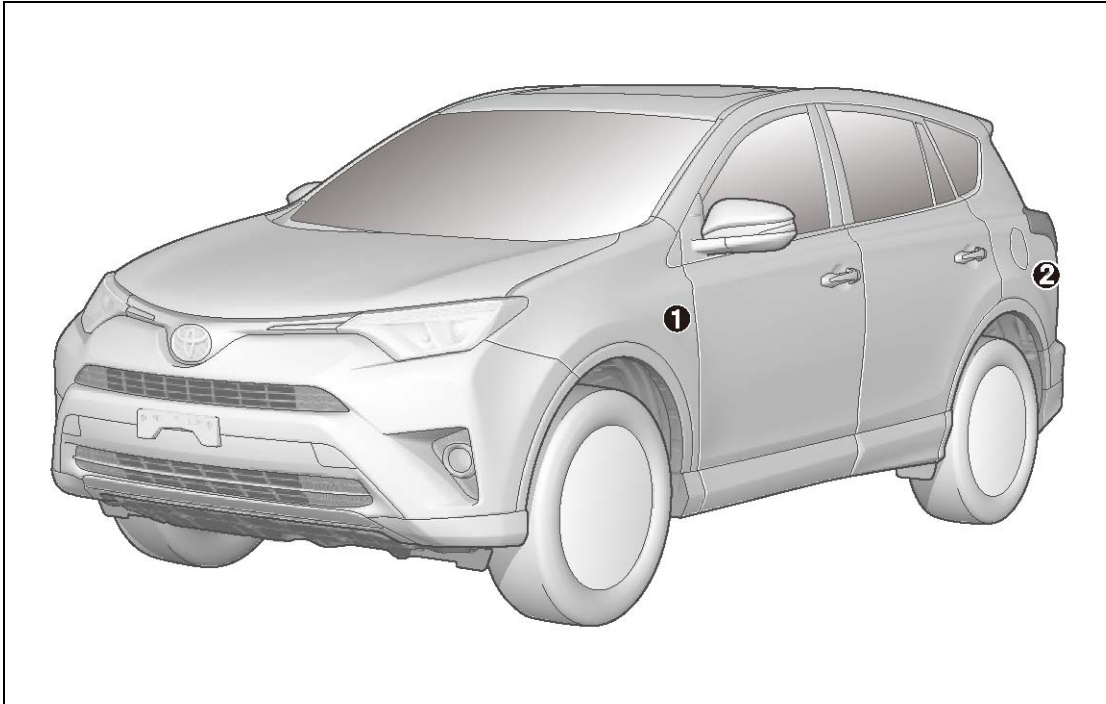

Exterior Front and Left Side View

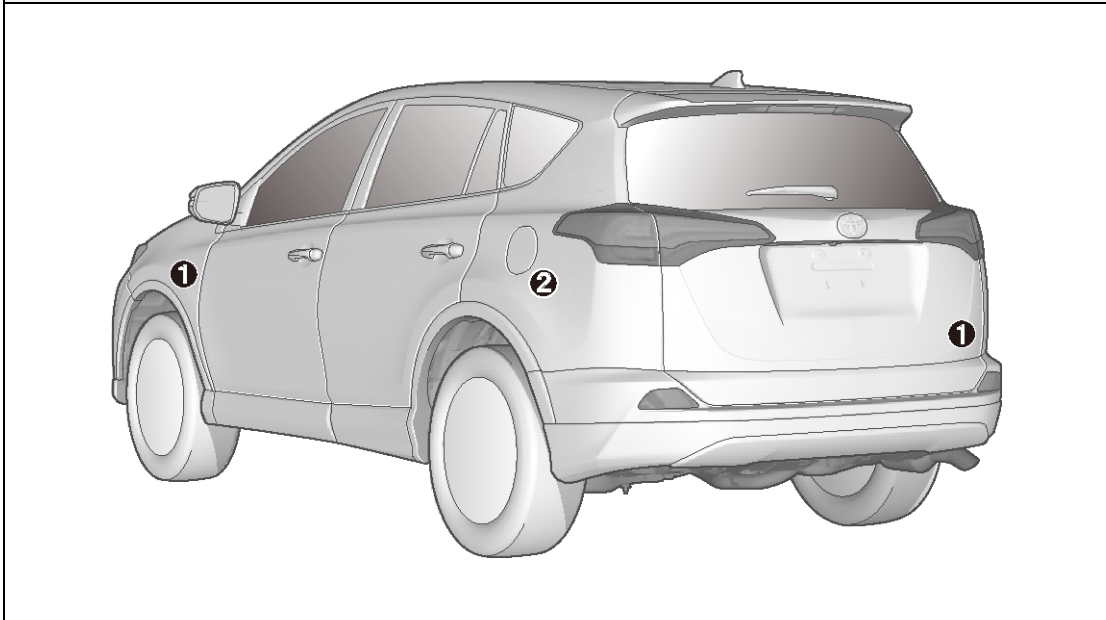

Exterior Rear and Left Side View

RAV4 Hybrid Identification (Continued)

Interior

- 3 The combination meter (hybrid system indicator, **READY** indicator and warning lights) located in the dash behind the steering wheel, is different than the one on the conventional, non-hybrid RAV4.

Notice:

If the vehicle is shut off, the combination meter gauges will be “blacked out”, not illuminated.

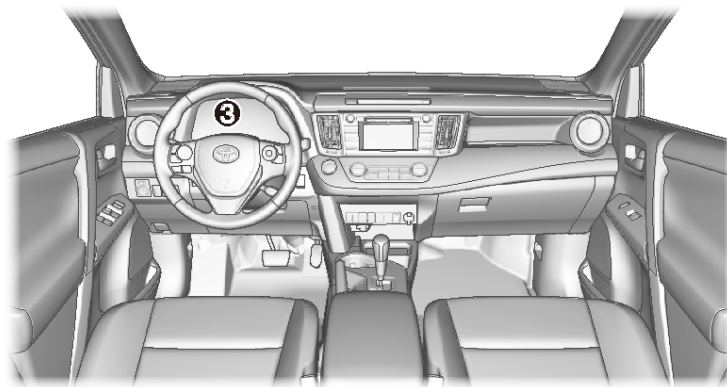

This illustration is for an LHD model

Interior View

3

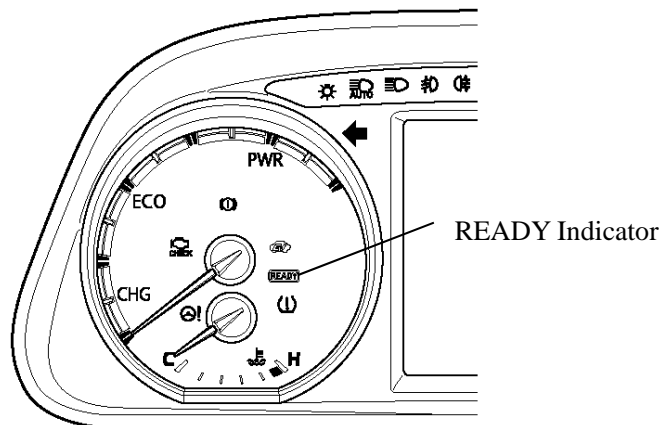

Combination Meter View

RAV4 Hybrid Identification (Continued)

Engine Compartment

- ④ 2.5-liter aluminum alloy gasoline engine.
- ⑤ Logo on the plastic No. 1 Engine Cover Sub-assembly.
- ⑥ Orange colored high voltage power cables.

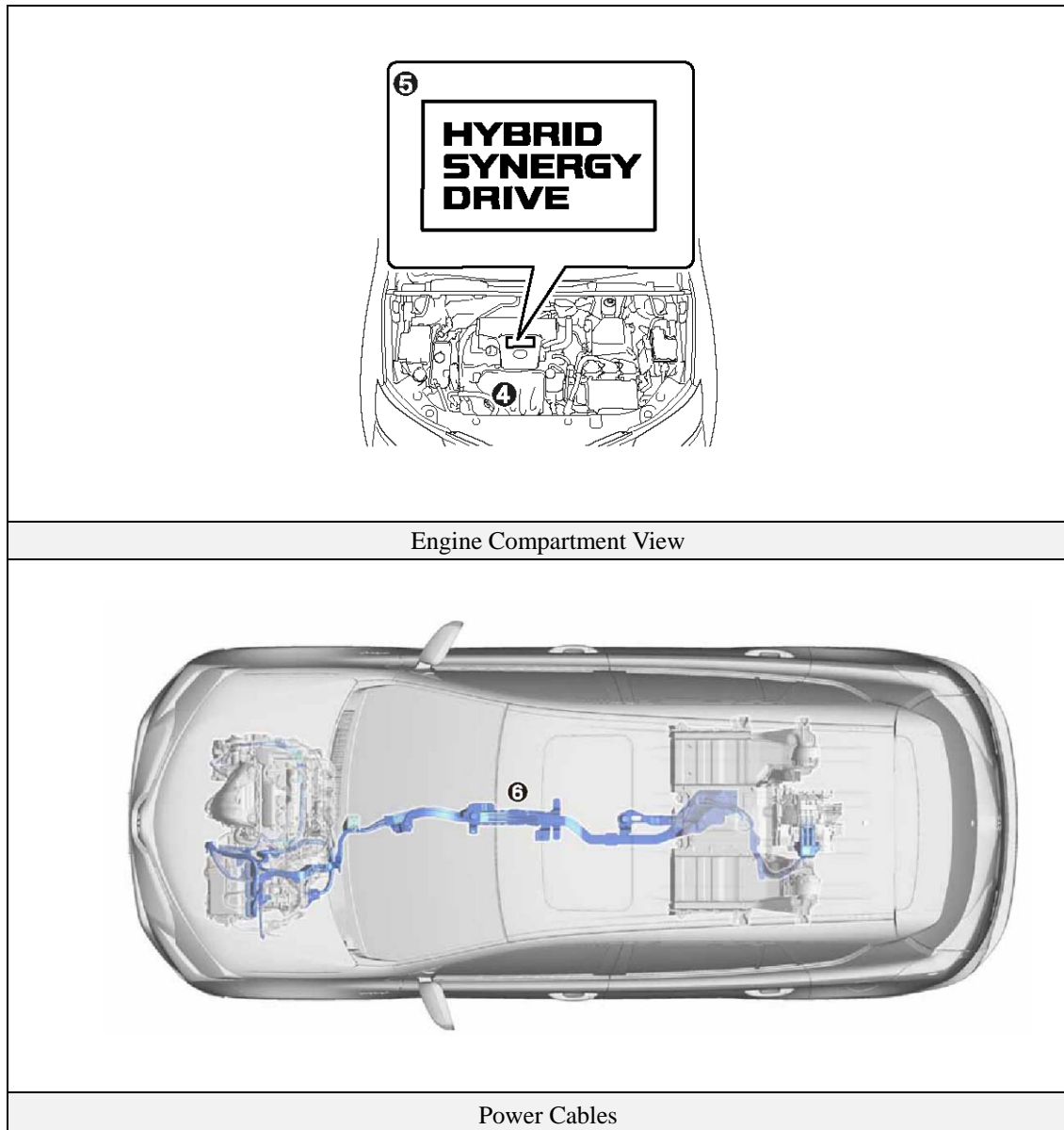

Hybrid Component Locations & Descriptions

Component		Description
12 V Auxiliary Battery ❶		When the power switch is on ACC or on IG, the auxiliary battery supplies power to the electrical equipment and ECUs.
Hybrid Vehicle (HV) Battery Pack ❷		<ul style="list-style-type: none"> · Supplies electrical power to the electric generator (MG1), front electric motor (MG2) and rear electric motor (MGR) and the A/C compressor in accordance with the driving conditions of the vehicle. · Charged by the electric generator (MG1) and electric motor (MG2) in accordance with the State Of Charge (SOC) of the HV battery and the driving conditions of the vehicle. · Has a nominal (approximate) voltage of DC 244.8 V (actual voltage will vary depending on various conditions such as temperature, charge or discharge).
Power Cables ❸		Connects the HV battery to the Inverter/Converter, the Inverter/Converter to electric generator (MG1), front electric motor (MG2) and rear electric motor (MGR), and the Inverter/Converter to the A/C Compressor.
Inverter/Converter ❹	DC-DC Converter ❺ for 12 V Auxiliary Battery	Reduces the HV battery voltage from DC 244.8 V to approximately DC 14 V in order to supply electricity to body electrical components, as well as to recharge the auxiliary battery.
	Motor Generator ECU	Controls the boost converter and inverter in accordance with signals received from the hybrid vehicle control ECU, operating electric generator (MG1), front electric motor (MG2) or rear electric motor (MGR) as either a generator or motor.
	Boost Converter	Boosts the voltage of the HV battery from DC 244.8 V to a maximum of DC 650 V and vice versa (reduces from DC 650 V to DC 244.8 V).
	Inverter	Converts high-voltage DC (HV battery) into AC (electric generator (MG1), front electric motor (MG2) and rear electric motor (MGR)) and vice versa (converts AC into DC).
Gasoline Engine ❻		Is a high-expansion ratio Atkinson cycle engine which is compatible with the hybrid system and which generates drive force for driving and energy for electricity generation.
Front Electric Motor ❼		<ul style="list-style-type: none"> · Driven by electrical power from the electric generator (MG1) and/or the HV battery, and generates motive force for the front wheels. · Generates electricity to recharge the HV battery (regenerative braking) during braking or when the accelerator pedal is not depressed.
Rear Electric Motor ❸		Driven by electrical power from the electric generator (MG1) and/or the HV battery, it generates motive force for the rear wheels.
Electric Generator ❹		<ul style="list-style-type: none"> · Driven by the engine and generates high-voltage electricity in order to operate the front electric motor (MG2) and rear electric motor (MGR) and/or to charge the HV battery. Also, the electric generator (MG1) functions as a starter to start the engine. · Operated to allow the gear ratio of the power split planetary gear unit to optimally suit the driving conditions of the vehicle.
A/C Compressor (with inverter) ❿		Driven at a speed calculated by the air conditioning amplifier assembly, receives drive requests from the hybrid vehicle control ECU and takes in, compresses and discharges refrigerant.
Fuel Tank and Fuel Line ❶		The fuel tank provides gasoline via a fuel line to the engine. The fuel line is routed along the left side under the floor pan.

*Numbers in the component column apply to the illustrations on the following page.

Hybrid Component Locations & Descriptions (Continued)

Specifications

- Gasoline Engine: 150 hp (112 kW), 2.5-liter Aluminum Alloy Engine
153 hp (114 kW), 2.5-liter Aluminum Alloy Engine (Except U.S.A.)
- Electric Motors:
Front: 141 hp (105 kW), Permanent Magnet Motor
Rear: 67 hp (50 kW), Permanent Magnet Motor (Only AWD)
- Transmission: Automatic Only (electrically controlled continuously variable transaxle)
- HV Battery: 244.8 V Sealed NiMH-Battery
- Curb Weight: 3,560-3,950 lbs/1,615-1,792 kg
- Fuel Tank: 14.8 Imp gals/12.3 U.S. gals/56 liters
- Frame Material: Steel Unibody
- Body Material: Steel Panels
- Seating Capacity: 5 passenger

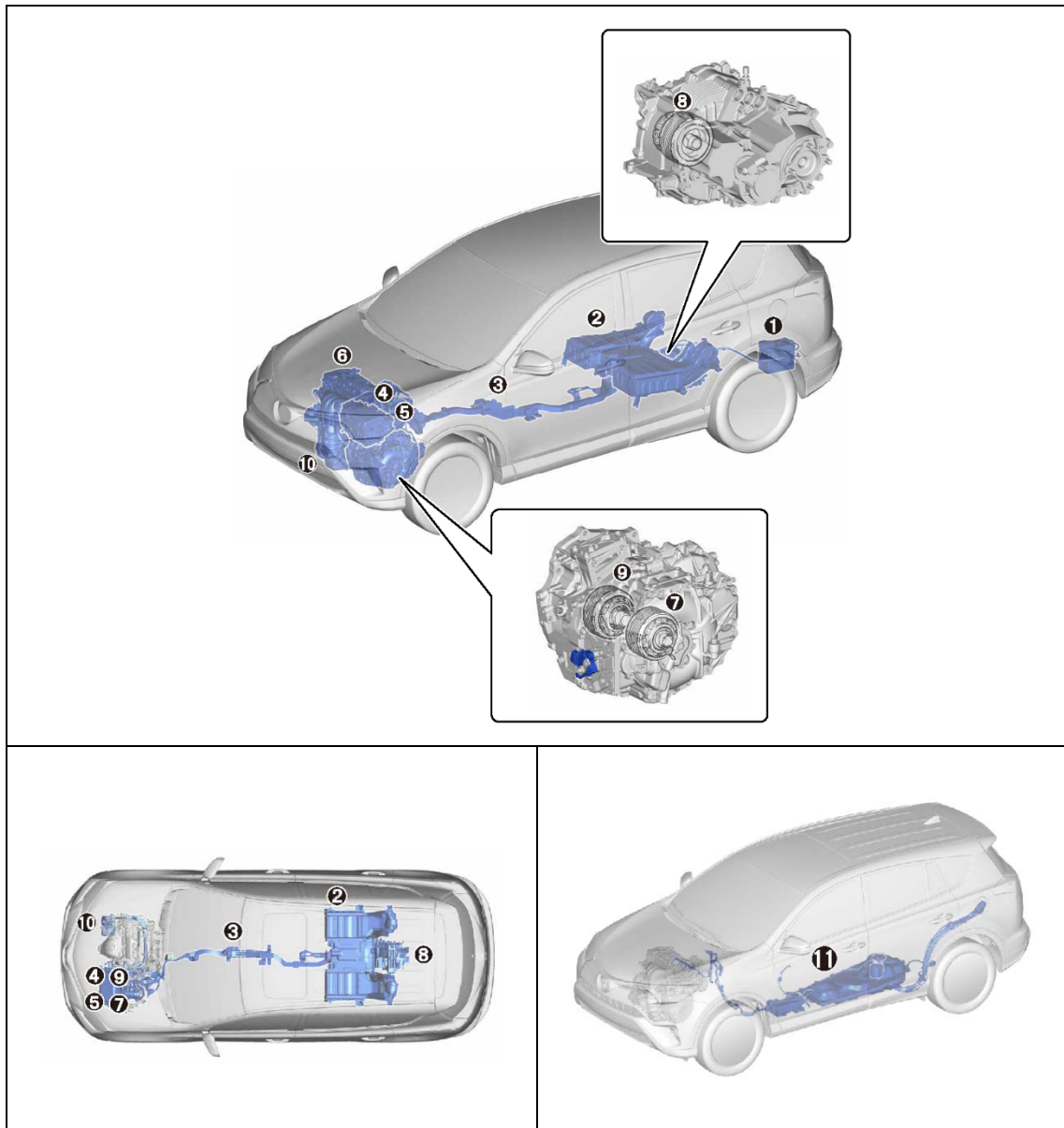

Hybrid Synergy Drive Operation

Once the **READY** indicator is illuminated in the combination meter, the vehicle may be driven. However, the gasoline engine does not idle like a typical automobile and will start and stop automatically. It is important to recognize and understand the **READY** indicator provided in the instrument cluster. When illuminated, it informs the driver that the vehicle is on and operational even though the gasoline engine may be off and the engine compartment is silent.

Vehicle Operation

- With the RAV4 Hybrid, the gasoline engine may stop and start at any time while the **READY** indicator is on.
- Never assume that the vehicle is shut off just because the engine is off. Always look for the **READY** indicator status. The vehicle is shut off when the **READY** indicator is off.

The vehicle may be powered by:

1. The electric motors only.
2. A combination of both the electric motors and the gasoline engine.

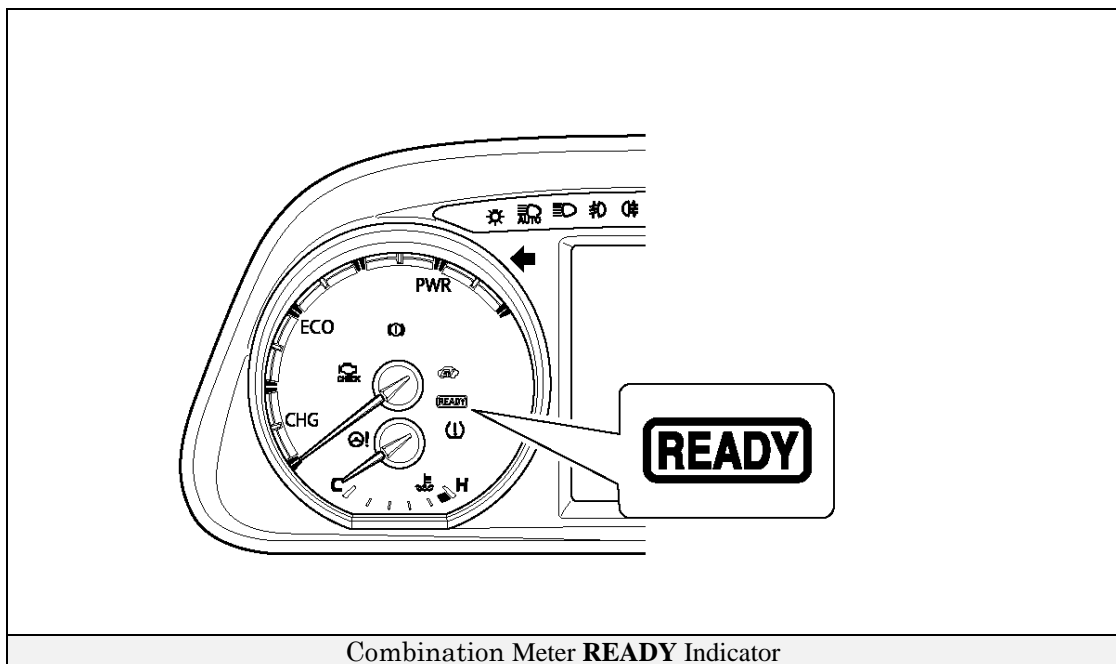

Hybrid Vehicle (HV) Battery Pack and Auxiliary Battery

The RAV4 Hybrid features a high voltage Hybrid Vehicle (HV) battery pack that contains sealed Nickel Metal Hydride (NiMH) battery modules.

HV Battery Pack

- The HV battery pack is enclosed in a metal case and is rigidly mounted to the cabin area under the front seats. The metal case is isolated from high voltage and concealed by fabric covers in the cabin area.
- The HV battery pack consists of 34 low voltage (7.2 V) NiMH battery modules connected in series to produce approximately 244.8 V. Each NiMH battery module is non-spillable and sealed in a metal case.
- The electrolyte used in the NiMH battery module is an alkaline mixture of potassium and sodium hydroxide. The electrolyte is absorbed into the battery cell plates and will not normally leak, even in a collision.

HV Battery Pack	
Battery pack voltage	244.8 V
Number of NiMH battery modules in the pack	34
NiMH battery module voltage	7.2 V

Components Powered by the HV Battery Pack

- Front Electric Motor
- Rear Electric Motor
- Power Cables
- A/C Compressor
- Electric Generator
- Inverter/Converter
 - DC-DC Converter for 12 V Auxiliary Battery

Hybrid Vehicle (HV) Battery Pack and Auxiliary Battery (Continued)

HV Battery Pack Recycling

- The HV battery pack is recyclable. Contact either your Toyota distributor as mentioned on the caution label on the HV battery or the nearest Toyota dealer.

Auxiliary Battery

- The RAV4 Hybrid also contains a sealed lead-acid 12 V battery. This 12 V auxiliary battery powers the vehicle electrical system similar to a conventional vehicle. As with other conventional vehicles, the auxiliary battery is grounded to the metal chassis of the vehicle.
- The auxiliary battery is located in the cargo area. It is concealed by a plastic resin cover on the left side in the rear quarter panel well.

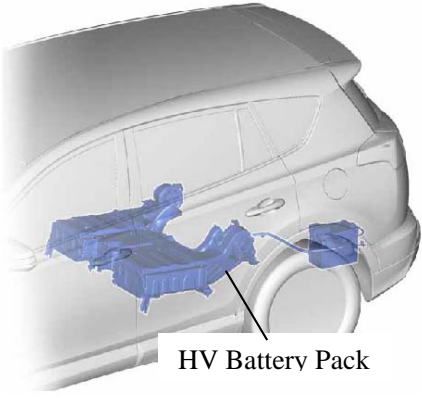
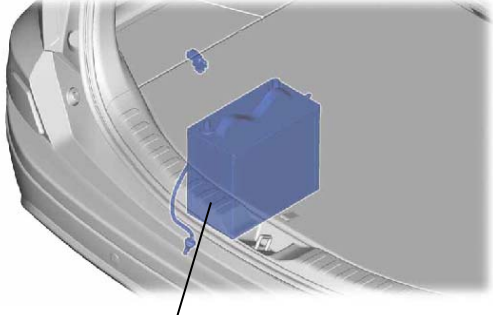
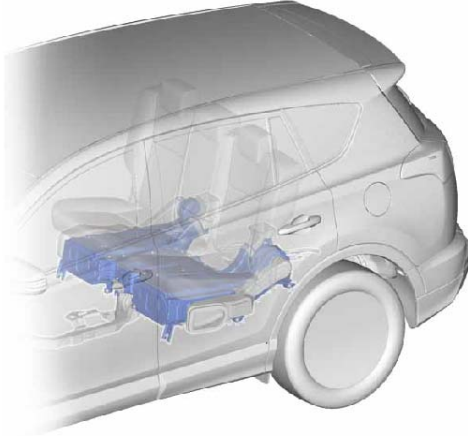
 <p>HV Battery Pack</p>	 <p>Auxiliary Battery</p>
244.8 V HV Battery Pack	12 V Auxiliary Battery Mounted in Cargo Area (Left Side)
	
HV Battery Pack Mounted in Cabin Area	

High Voltage Safety

The HV battery pack powers the high voltage electrical system with DC electricity. Positive and negative orange colored high voltage power cables are routed from the battery pack, under the vehicle floor pan, to the inverter/converter. The inverter/converter contains a circuit that boosts the HV battery voltage from 244.8 to 650 V DC. The inverter/converter creates 3-phase AC to power the motors. Power cables are routed from the inverter/converter to each high voltage motors (front and rear electric motors, electric generator, and A/C compressor). The following systems are intended to help keep occupants in the vehicle and emergency responders safe from high voltage electricity:

High Voltage Safety System

- A high voltage fuse ❶* provides short circuit protection in the HV battery pack.
- Positive and negative high voltage power cables ❷* connected to the HV battery pack are controlled by 12 V normally open relays ❸*. When the vehicle is shut off, the relays stop electricity flow from leaving the HV battery pack.



WARNING:

- ***The high voltage system may remain powered for up to 10 minutes after the vehicle is shut off or disabled. To prevent serious injury or death from severe burns or electric shock, avoid touching, cutting, or opening any orange high voltage power cable or high voltage component.***

- Both positive and negative power cables ❷* are insulated from the metal body. High voltage electricity flows through these cables and not through the metal vehicle body. The metal vehicle body is safe to touch because it is insulated from the high voltage components.
- A ground fault monitor ❹* continuously monitors for high voltage leakage to the metal chassis while the vehicle is running. If a malfunction is detected, the hybrid vehicle computer ❺* will illuminate the master warning light  in the instrument cluster and indicate “Hybrid system malfunction” on the multi-information display.
- The HV battery pack relays will automatically open to stop electricity flow in a collision sufficient to activate the SRS.

*Numbers apply to the illustration on the following page.

High Voltage Safety (Continued)

Service Plug Grip

- The high voltage circuit is cut by removing the service plug grip (see page 15).

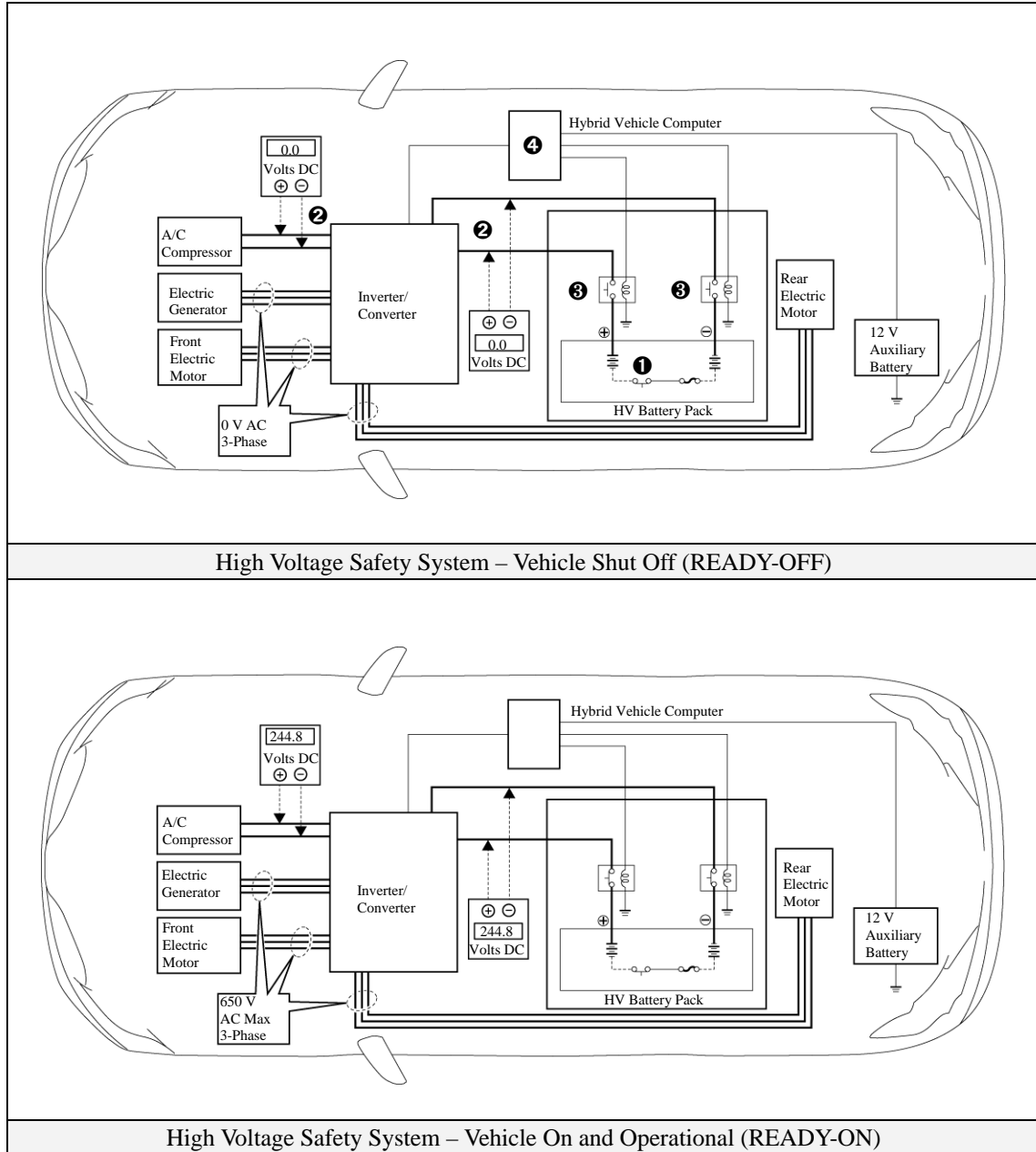

Precaution to be observed when dismantling the vehicle



WARNING:

- *The high voltage system may remain powered for up to 10 minutes after the vehicle is shut off or disabled. To prevent serious injury or death from severe burns or electric shock, avoid touching, cutting, or opening any orange high voltage power cable or high voltage component.*

Necessary Items

- Protective clothing such as insulated gloves (electrically insulated), rubber gloves, safety goggles, and safety shoes.
- Insulating tape such as electrical tape that has a suitable electrical insulation rating.
- Before wearing insulated gloves, make sure that they are not cracked, ruptured, torn, or damaged in any way. Do not wear wet insulated gloves.
- An electrical tester that is capable of measuring DC 750 V or more.

Spills

The RAV4 Hybrid contains the same common automotive fluids used in other non-hybrid Toyota vehicles, with the exception of the NiMH electrolyte used in the HV battery pack. The NiMH battery electrolyte is a caustic alkaline (pH 13.5) that is damaging to human tissues. The electrolyte, however, is absorbed in the cell plates and will not normally spill or leak out even if a metal battery module is cracked.

A catastrophic crash that would breach both the metal battery pack case and a metal battery module would be a rare occurrence.

A caustic alkaline is at the opposite end of the pH scale from a strong acid. A safe (neutral) substance is approximately in the middle of this scale. Adding a weak acidic mixture, such as a dilute boric acid solution or vinegar, to the caustic alkaline electrolyte will cause the electrolyte to be neutralized. This is similar but opposite to the use of baking soda to neutralize a lead-acid battery electrolyte spill.

- Handle NiMH electrolyte spills using the following Personal Protective Equipment (PPE):
 - Splash shield or safety goggles. A fold down face shield is not acceptable for acid or electrolyte spills.
 - Rubber, latex or nitrile gloves.
 - Apron suitable for alkaline.
 - Rubber boots.

- Neutralize NiMH electrolyte.
 - Use a boric acid solution or vinegar.
 - Boric acid solution - 800 grams boric acid to 20 liters water or 5.5 ounces boric acid to 1 gallon of water.

Dismantling the vehicle

The following 5 pages contain general instructions for use when working on a RAV4 Hybrid.

Read these instructions before proceeding to the HV battery removal instructions on page 20.



WARNING:

- ***The high voltage system may remain powered for up to 10 minutes after the vehicle is shut off or disabled. To prevent serious injury or death from severe burns or electric shock, avoid touching, cutting, or opening any orange high voltage power cable or any high voltage component.***

1. Shut off the ignition (**READY** indicator is off).

Then disconnect the cable from negative auxiliary battery terminal.

- (1) Remove the package tray trim pocket sub-assembly (w/ partition net)

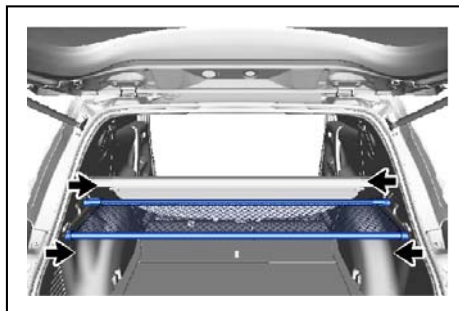

- (2) Remove the tonneau cover assembly (w/ tonneau cover)

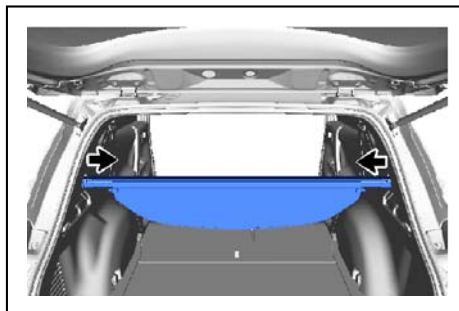

- (3) Remove the deck board assembly.

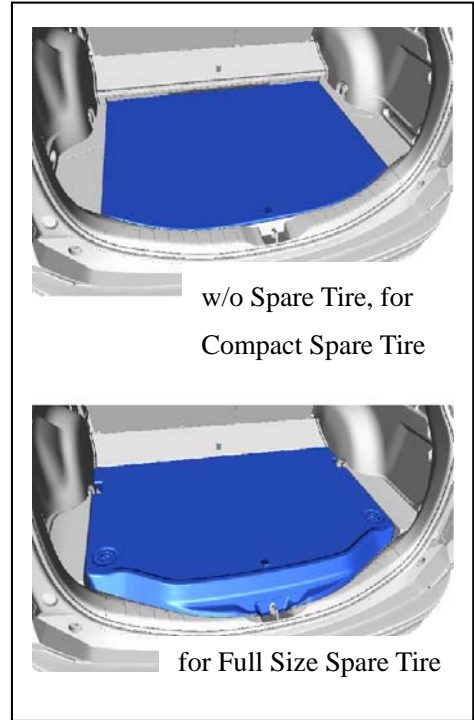

- (4) Detach the 4 claws and remove the battery service cover.
- (5) Loosen the nut and disconnect the cable from the negative (-) auxiliary battery terminal.

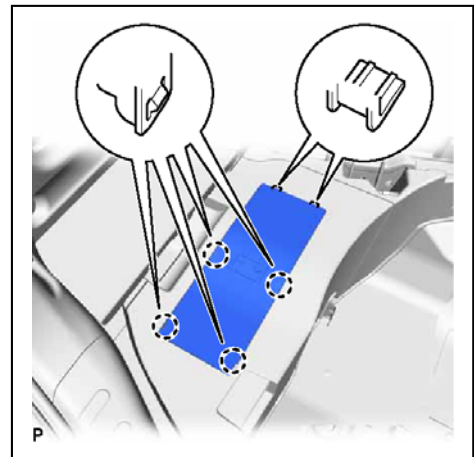

2. Remove the service plug grip.

- (1) Remove the battery service hole cover.

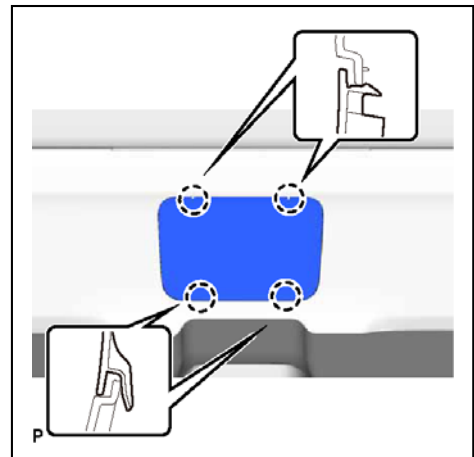

(2) Remove the hybrid battery service plug cover.

Caution:

Wear insulated gloves and use insulated tools.

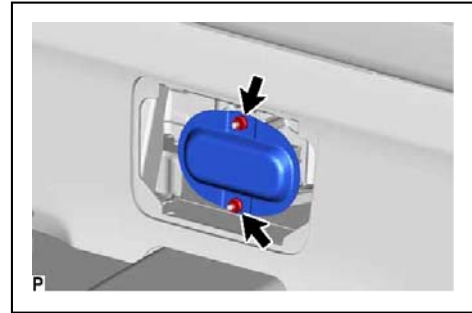

(3) Remove the service plug grip.

Caution:

- **Be sure to wear insulated gloves.**
- **Remove the service plug grip to interrupt the high voltage circuit at the time of inspection or repair.**
- **Keep the removed service plug grip in your pocket to prevent other technicians from accidentally reconnecting it while you are servicing the vehicle.**
- **All the high voltage wiring connectors are orange.**

- Wear insulated gloves and remove the service plug grip after sliding up the lever of the service plug grip as shown in the illustration.

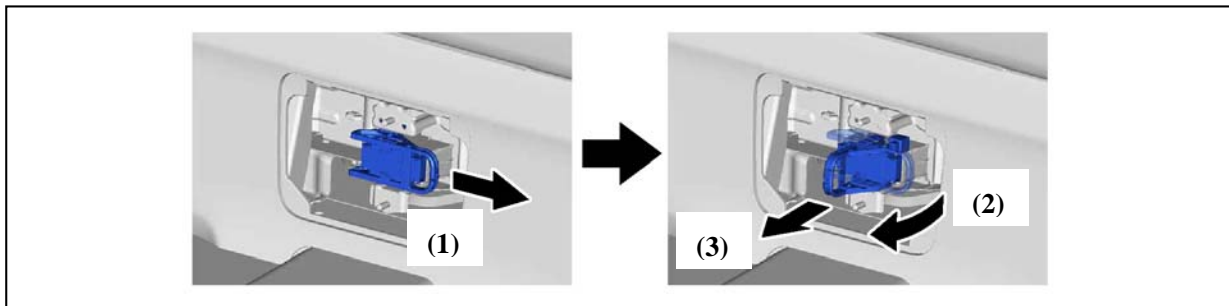

- ① Slide the lever to release the lock.
- ② Lift the lever straight up.

Notice:

Do not exert excessive force to lift up the lever.

- ③ Pull the service plug grip out from the HV battery to remove it.

3. Carry the removed service plug grip in your pocket to prevent other staff from accidentally reinstalling it while you are dismantling the vehicle.
4. Make other staff aware that a high-voltage system is being dismantled by using the following sign: CAUTION: HIGH-VOLTAGE. DO NOT TOUCH (see page 19).
5. If the service plug grip cannot be removed due to damage to the vehicle, remove the **IG2-MAIN** fuse (20 A).

Caution:

This operation shuts off the HV system. Be sure to wear insulated gloves because high voltage is not shut off inside the HV battery. When it is possible to remove the service plug grip, remove it and continue the procedure.

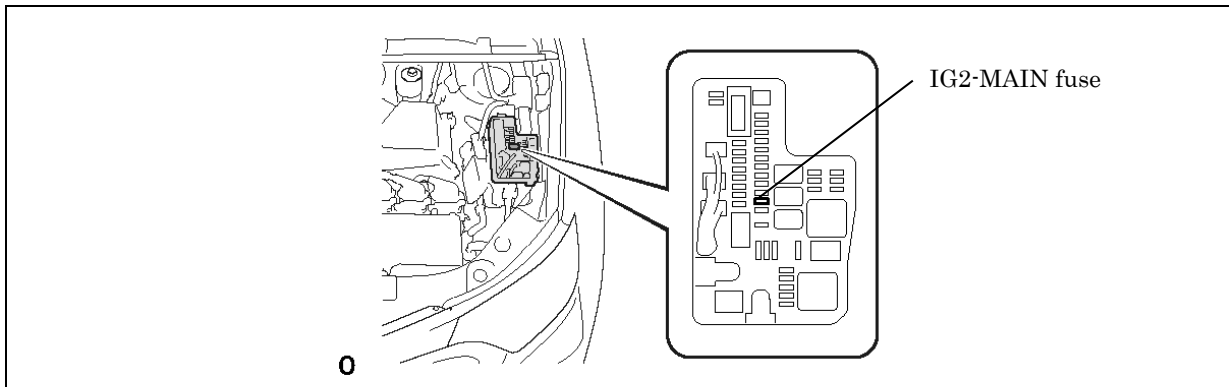

6. After disconnecting or exposing a high-voltage connector or terminal, insulate it immediately using insulating tape. Before disconnecting or touching a bare high-voltage terminal, wear insulated gloves.
7. Check the HV battery and nearby area for leakage. If you find any liquid, it may be strong alkaline electrolyte. Wear rubber gloves and goggles and neutralize the liquid using a saturated boric acid solution or vinegar. Then wipe up the liquid using waste rags etc.
8. If the electrolyte comes into contact with your skin, wash the skin immediately using a saturated boric acid solution or a large amount of water. If the electrolyte adheres to any article of clothing, take the clothing off immediately.
9. If the electrolyte comes into contact with your eye(s), call out loudly for help. Do not rub your eye(s). Instead, wash the eye(s) with a dilute boric acid solution or a large amount of water and seek medical care.
10. With the exception of the HV battery, remove parts by following procedures which are similar to conventional Toyota vehicles. For the removal of the HV battery, refer to the following pages.

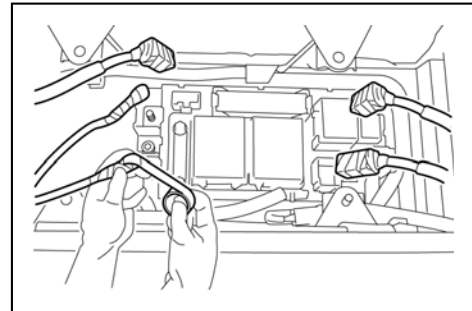

Person in charge: _____

CAUTION:
HIGH-VOLTAGE.
DO NOT TOUCH.

CAUTION:
HIGH-VOLTAGE.
DO NOT TOUCH.

Person in charge: _____

When performing work on the HV system, fold this sign and put it on the roof of the vehicle.

Removal of HV battery



WARNING:

- *Be sure to wear insulated gloves when handling high-voltage parts.*
- *Even if the vehicle is shut off and the relays are off, be sure to remove the service plug grip before performing any further work.*
- *Power remains in the high voltage electrical system for 10 minutes even after the HV battery pack is shut off because the circuit has a condenser that stores power.*
- *Make sure that the tester reading is 0 V before touching any high-voltage terminals which are not insulated.*
- *The SRS may remain powered for up to 90 seconds after the vehicle is shut off or disabled. To prevent serious injury or death from unintentional SRS deployment, avoid cutting the SRS components.*

1. SHUT OFF IGINATION (**READY** indicator is off)
2. REMOVE PACKAGE TRAY TRIM POCKET SUB-ASSEMBLY (w/ PartitionNet)
 - (1) Release the 4 locks and remove the package tray trim pocket sub-assembly.

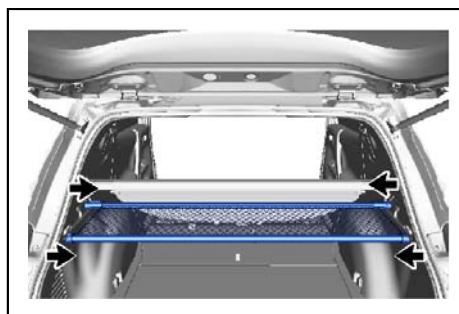

3. REMOVE TONNEAU COVER ASSEMBLY (w/ Tonneau Cover)
 - (1) Release the 2 locks and remove the tonneau cover assembly.

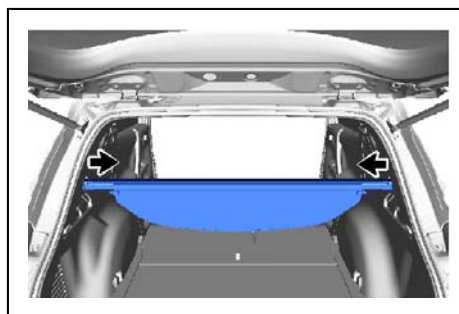

4. REMOVE DECK BOARD ASSEMBLY

- (1) Remove the deck board assembly.

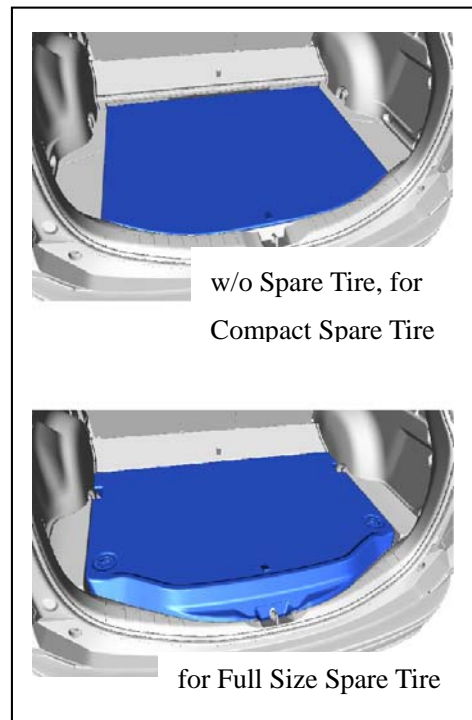

5. DISCONNECT CABLE FROM NEGATIVE AUXILIARY BATTERY TERMINAL

- (1) Detach the 4 claws and remove the battery service cover.
- (2) Loosen the nut and disconnect the cable from the negative (-) auxiliary battery terminal.

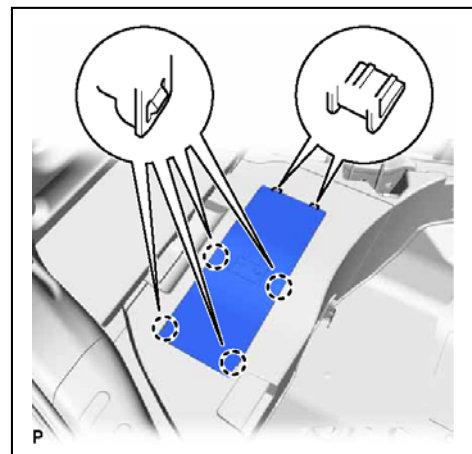

6. REMOVE BATTERY SERVICE HOLE COVER

- (1) Detach the 4 claws and remove the battery service hole cover.

Hint:

Detach the upper 2 claws and then pull them up to remove.

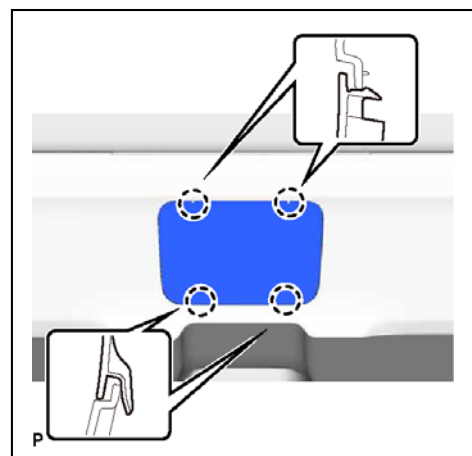

7. REMOVE HYBRID BATTERY SERVICE PLUG COVER

Caution:

Wear insulated gloves and use insulated tools.

- (1) Using an insulated tool, remove the 2 nuts and hybrid battery service plug cover.

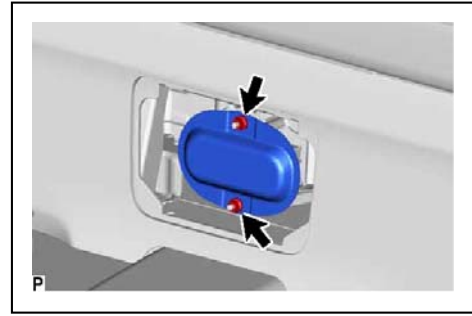

8. REMOVE SERVICE PLUG GRIP

Caution:

- Be sure to wear insulated gloves.
- Remove the service plug grip to interrupt the high voltage circuit at the time of inspection or repair.
- Keep the removed service plug grip in your pocket to prevent other technicians from accidentally reconnecting it while you are servicing the vehicle.
- All the high voltage wiring connectors are orange.

- (1) Wear insulated gloves and remove the service plug grip after sliding up the lever of the service plug grip as shown in the illustration.

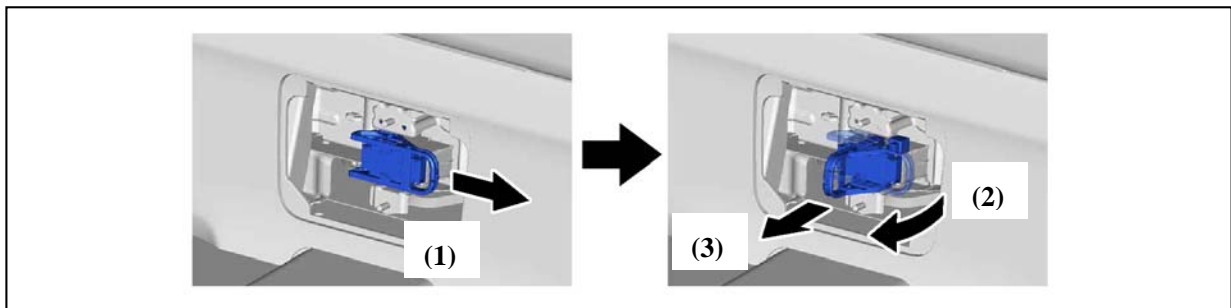

- i. Slide the lever to release the lock.
- ii. Lift the lever straight up.

Notice:

Do not exert excessive force to lift up the lever.

- iii. Pull the service plug grip out from the HV battery to remove it.

9. DISCONNECT WIRE HARNESS

- (1) Disconnect the 4 wire harness clamps from the inverter reserve tank assembly and inverter with converter assembly.

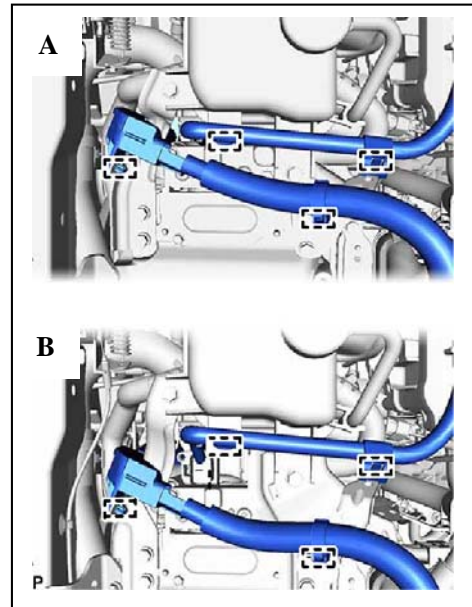

A	for AWD
B	for 2WD

10. DISCONNECT INVERTER RESERVE TANK ASSEMBLY

- (1) Slide the hose clamp, and disconnect the water hose from the inverter reserve tank assembly.
- (2) Remove the 2 bolts, and disconnect the inverter reserve tank assembly from the inverter reserve tank bracket.
- (3) Slide the retainer as shown in the illustration, disconnect the No. 1 inverter cooling hose assembly, and remove the inverter reserve tank assembly.

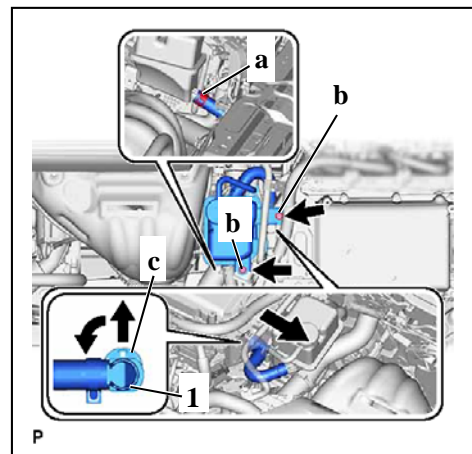

1	Quick Connector
a	Hose Clamp
b	Bolt
c	Retainer

Notice:

Cover the disconnected water hose and pipe with a plastic bag and tape to prevent coolant from splattering.

Hint:

Turn the quick connector to the left, then release the retainer to prevent it from interfering with the inverter bracket.

11. REMOVE NO. 1 INVERTER RESERVE TANK BRACKET (for 2WD)

- (1) Remove the 2 bolts and No. 1 inverter reserve tank bracket.

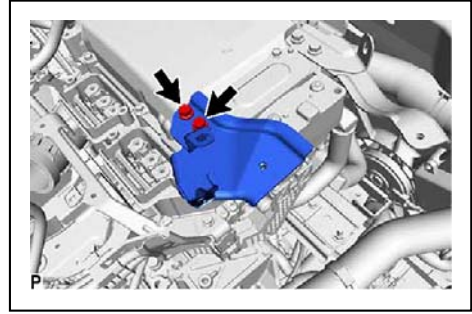

12. REMOVE CONNECTOR COVER ASSEMBLY

Caution:

Be sure to wear insulated gloves.

- (1) Using an insulated tool, remove the 2 bolts and connector cover assembly.

Notice:

Pull the connector cover assembly straight up, as a connector is connected to the bottom of the cover.

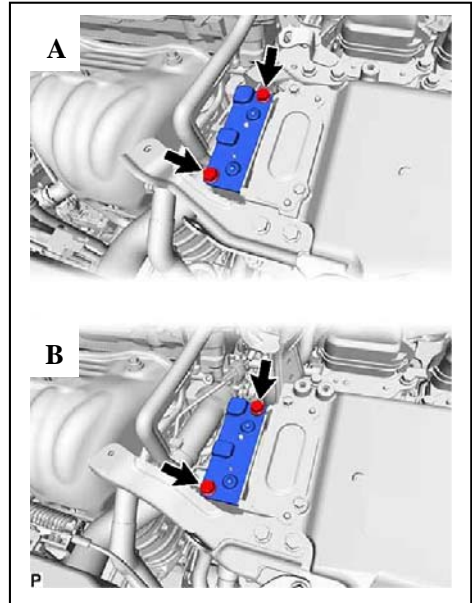

A	for AWD
B	for 2WD

13. CHECK TERMINAL VOLTAGE

- (1) Using a voltmeter, measure the voltage between the terminals of the 2 phase connectors.

Standard voltage: 0 V

Hint:

Use a measuring range of DC 750 V or more on the voltmeter.

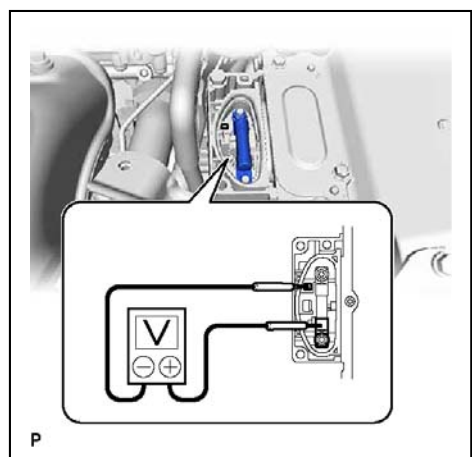

14. REMOVE BENCH TYPE REAR SEAT CUSHION ASSEMBLY

- (1) Lift the front end of the rear seat cushion assembly as shown in the illustration and detach the 2 hooks from the rear seat cushion lock hook section.
- (2) Detach the 2 hooks of the rear of the rear seat cushion frame.

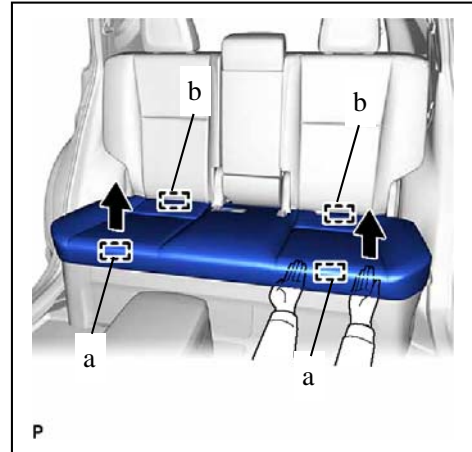

a	Rear seat cushion lock hook section
b	Hook section at rear of rear seat cushion frame

- (3) w/ Seat Heater System:
 - i. Disconnect the 2 connectors.
- (4) Pass the rear seat inner with center belt assembly RH through the rubber band of the rear seat cushion assembly.
- (5) Remove the bench type rear seat cushion assembly.



15. REMOVE RECLINING ADJUSTER RELEASE HANDLE LH

- (1) Using a screwdriver, detach the claw to remove the reclining adjuster release handle LH.

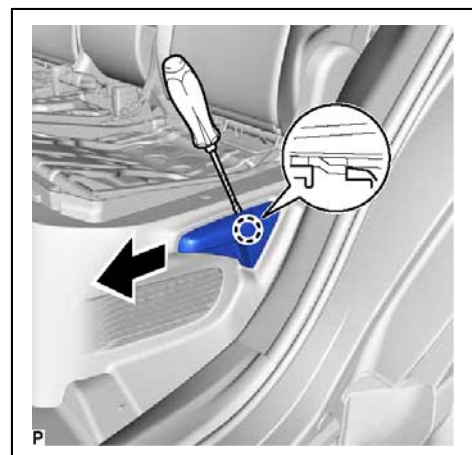

16. REMOVE RECLINING ADJUSTER RELEASE HANDLE RH

Hint:

Use the same procedure described for the LH side.

17. REMOVE REAR DOOR OPENING TRIM WEATHERSTRIP LH

- (1) Remove the rear door opening trim weatherstrip LH.



18. REMOVE REAR DOOR OPENING TRIM WEATHERSTRIP RH

Hint:

Use the same procedure described for the LH side.

19. REMOVE REAR DOOR SCUFF PLATE LH

- (1) Detach the 2 claws and 6 clips and remove the rear door scuff plate LH.

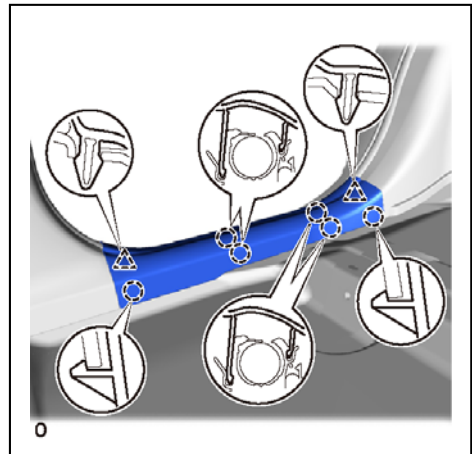

20. REMOVE REAR DOOR SCUFF PLATE RH

Hint:

Use the same procedure described for the LH side.

21. REMOVE NO. 3 BATTERY SERVICE COVER BOARD

- (1) Using a clip remover, remove the 2 clips.
- (2) Move the No. 3 battery service cover board in the direction indicated by the arrow shown in the illustration to detach the 2 clips and guide and remove the No. 3 battery service cover board.

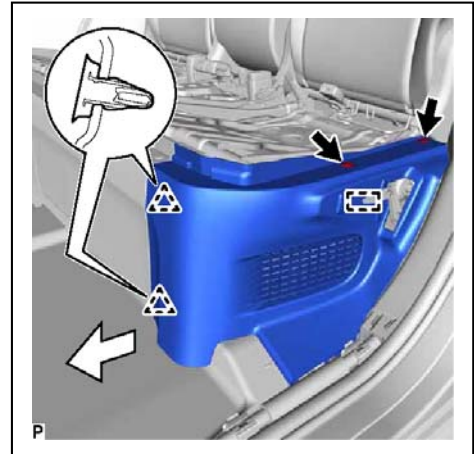

22. REMOVE NO. 2 BATTERY SERVICE COVER BOARD

Hint:

Use the same procedure described for the No. 3 battery service cover board.

23. REMOVE REAR SEATBACK ASSEMBLY LH

- (1) Operate the reclining adjuster release handle to fold down the rear seatback assembly LH.
- (2) Using a clip remover, detach the 4 clips.
- (3) Return the rear seatback assembly LH to the upright position.

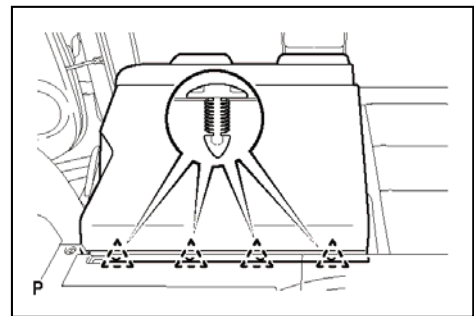

- (4) Using a screwdriver, detach the 2 claws.
- (5) Detach the 2 cable clamps.
- (6) Detach the cable end to disconnect the rear seat reclining control cable.

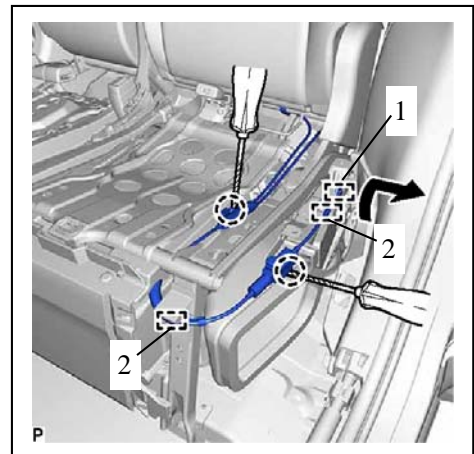

1	Cable End
2	Cable Clamp

(7) w/ Seat Belt Warning System:

- i. Disconnect the connector and detach the 2 clamps.

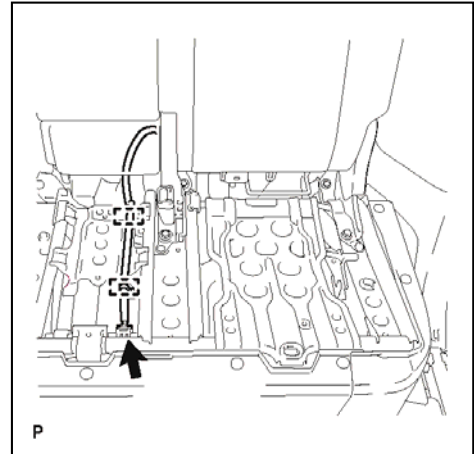

(8) w/ Seat Belt Warning System, w/ Seat Heater System:

- i. Disconnect the connector and detach the 3 clamps.

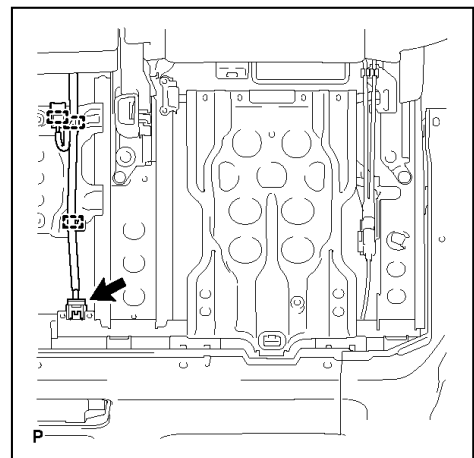

(9) Remove the 4 bolts.

(10) Detach the 2 guides to remove the rear seatback assembly LH.

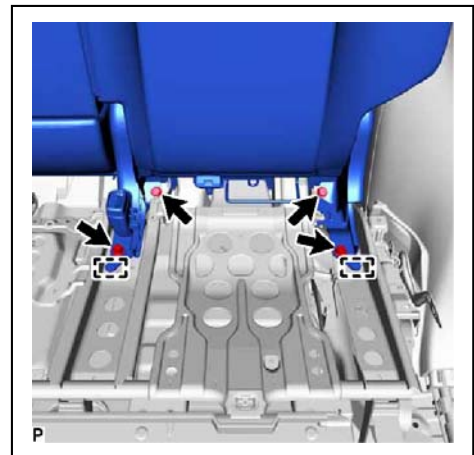

24. REMOVE REAR SEATBACK ASSEMBLY RH

- (1) Operate the reclining adjuster release handle to fold down the rear seatback assembly RH.
- (2) Using a clip remover, detach the 3 clips
- (3) Return the rear seatback assembly RH to the upright position.

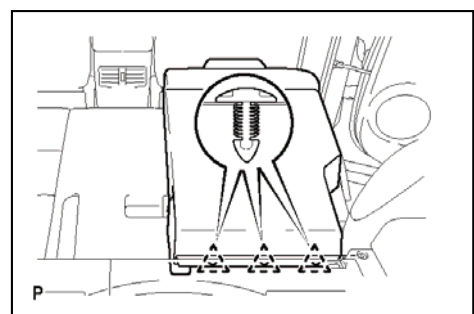

- (4) Using a screwdriver, detach the 2 claws.
- (5) Detach the 2 cable clamps.
- (6) Detach the cable end to disconnect the rear seat reclining control cable.

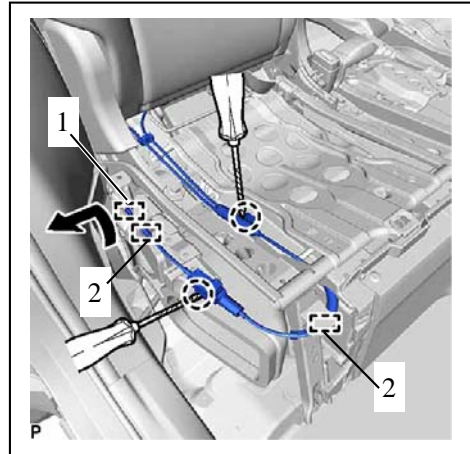

1	Cable End
2	Cable Clamp

- (7) w/ Seat Belt Warning System:
 - i. Disconnect the connector and detach the 2 clamps.

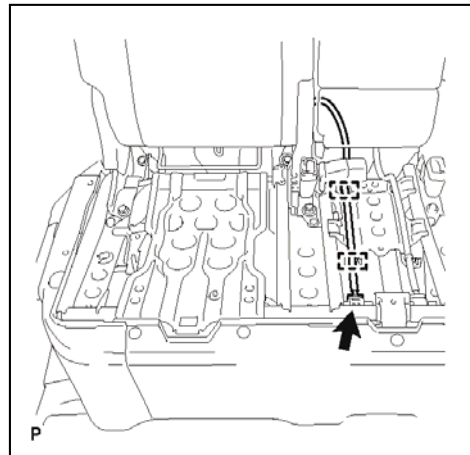

- (8) w/ Seat Belt Warning System, w/ Seat Heater System:
 - i. Disconnect the connector and detach the 3 clamps.

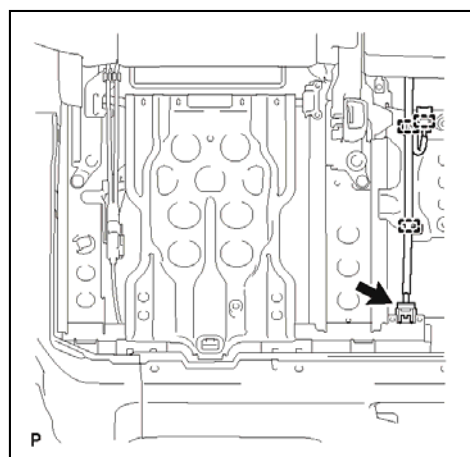

- (9) Remove the 4 bolts.
- (10) Detach the 2 guides to remove the rear seatback assembly RH.

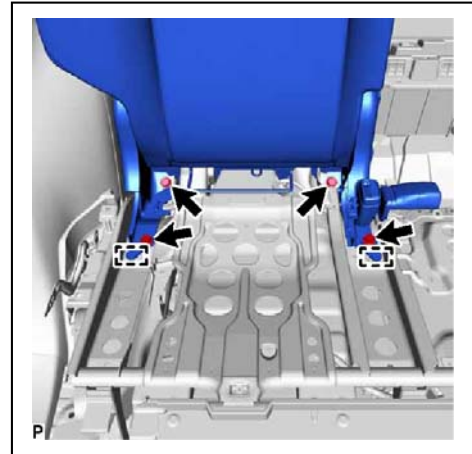

25. REMOVE BATTERY SERVICE COVER BOARD

- (1) Using a clip remover, remove the 5 clips.
- (2) Detach the 2 guides to remove the battery service cover board.

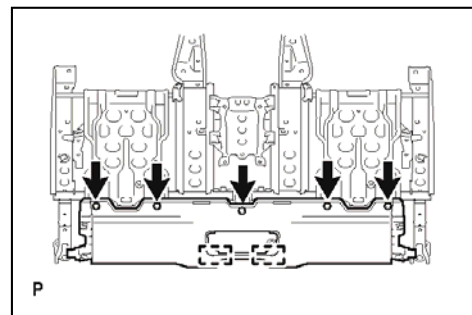

26. REMOVE REAR NO. 3 FLOOR BOARD

- (1) w/o Spare Tire, for Compact Spare Tire:
 - i. Detach the 2 clips and 2 guides and remove the rear No. 3 floor board.

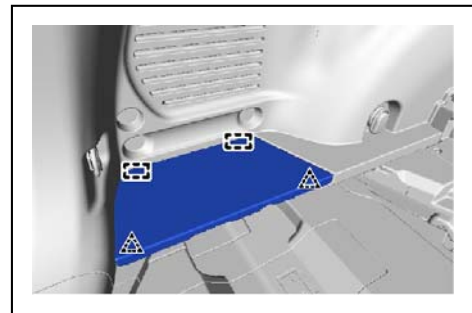

- (1) for Full Size Spare Tire:
 - i. Detach the 4 clips and remove the rear No. 3 floor board.

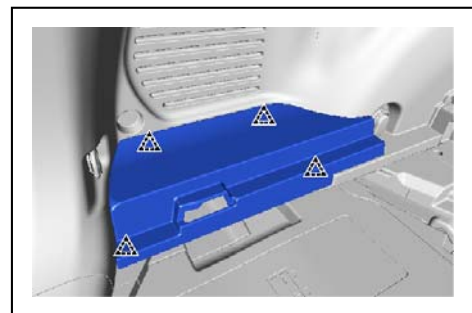

27. REMOVE REAR NO. 2 FLOOR BOARD

Hint:

Use the same procedure described for the rear No. 3 floor board side.

28. REMOVE DECK TRIM SIDE COVER BASE LH

- (1) w/o Spare Tire, for Compact Spare Tire:
 - i. Detach the 5 claws and 3 guides and remove the deck trim side cover base LH.

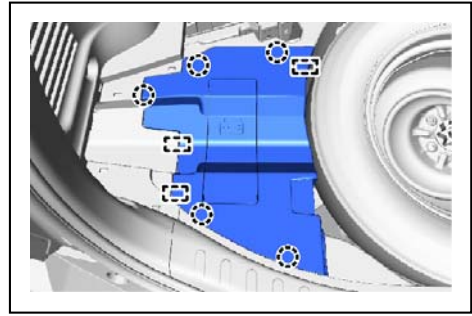

- (2) for Full Size Spare Tire:
 - i. Detach the 5 claws and 3 guides and remove the deck trim side cover base LH.

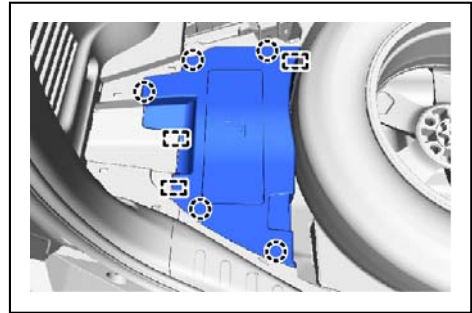

29. REMOVE DECK FLOOR BOX LH

- (1) w/o Spare Tire, for Compact Spare Tire:
 - i. Using a clip remover, remove the 2 clips.
 - ii. Detach the 2 claws and guide and remove the deck floor box LH.

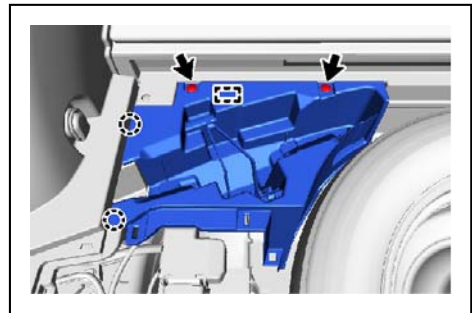

- (2) for Full Size Spare Tire:
 - i. Using a clip remover, remove the 2 clips.
 - ii. Detach the 2 claws and guide and remove the deck floor box LH.

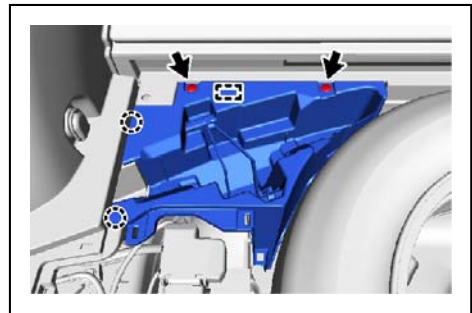

30. REMOVE REAR NO. 1 FLOOR MAT SUPPORT SIDE PLATE

- (1) Open the rear No. 1 floor board.
- (2) Remove the 4 screws.
- (3) Detach the 3 clips and 4 guides and remove the rear No. 1 floor mat support side plate together with the rear No. 1 floor board.

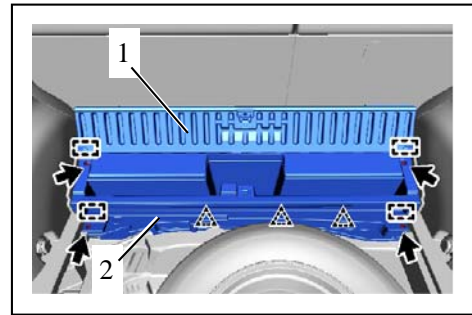

1	Rear No. 1 Floor Board
2	Rear No. 1 Floor Mat Support Side Plate

31. REMOVE NO. 1 SEAT LEG ASSEMBLY

- (1) Remove the 8 bolts.
- (2) Detach the 2 guides to remove the No. 1 seat leg assembly.

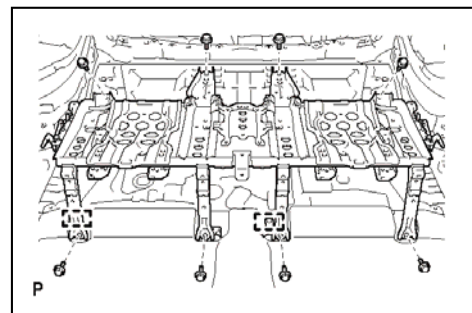

32. REMOVE DECK TRIM SERVICE HOLE COVER

Hint:

Use the same procedure for both deck trim service hole covers.

- (1) Using a screwdriver, detach the 4 claws and 2 guides and disconnect the deck trim service hole cover.

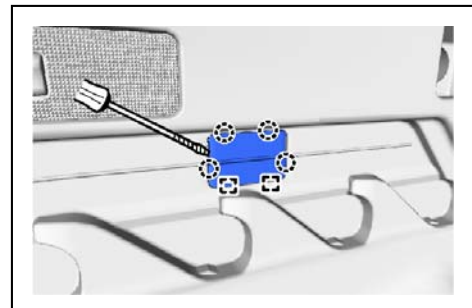

33. REMOVE DECK TRIM SIDE PANEL ASSEMBLY LH

- (1) Remove the screw and 2 bolts.
- (2) Open the tether anchor set bracket cover.
- (3) Remove the bolt and tether anchor set bracket.
- (4) Remove the bolt and luggage hold belt striker assembly.
- (5) Detach the 6 claws and 4 clips and remove the deck trim side panel assembly LH.
- (6) Disconnect the connector.

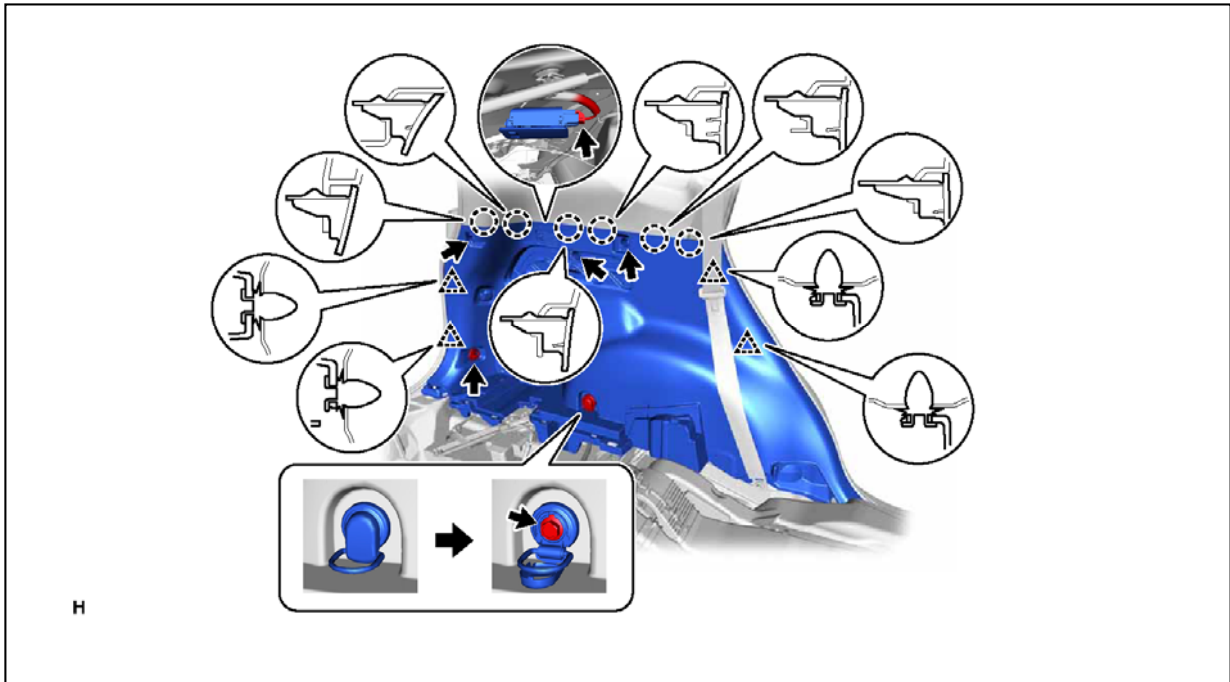

34. REMOVE DECK TRIM SIDE PANEL ASSEMBLY RH

- (1) Remove the screw and 2 bolts.
- (2) Open the tether anchor set bracket cover.
- (3) Remove the bolt and tether anchor set bracket.
- (4) Remove the bolt and luggage hold belt striker assembly.
- (5) Detach the 6 claws and 4 clips and remove the deck trim side panel assembly RH.

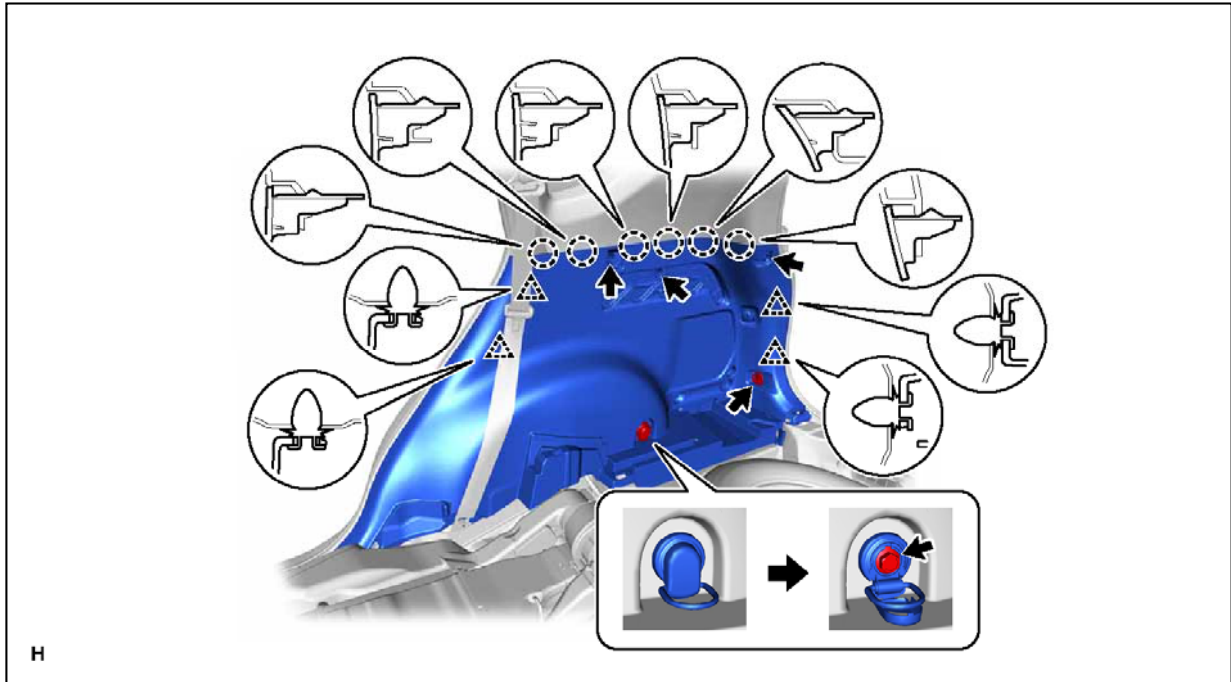

35. REMOVE NO. 2 HYBRID BATTERY INTAKE DUCT

- (1) Remove the 2 clips and No. 2 hybrid battery intake duct.

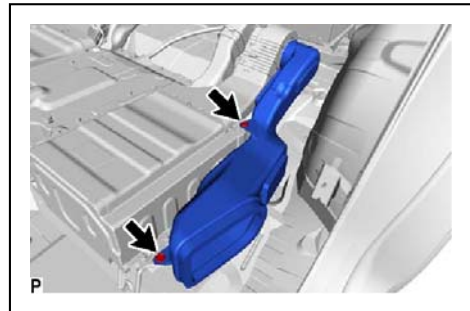

36. REMOVE NO. 1 HYBRID BATTERY INTAKE DUCT

- (1) Remove the 2 clips and No. 1 hybrid battery intake duct.

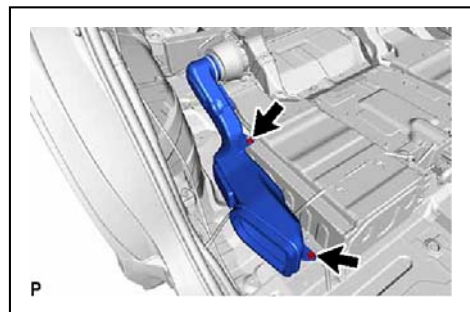

37. REMOVE NO. 2 HYBRID VEHICLE BATTERY SHIELD REINFORCEMENT

- (1) Using the service plug grip, release the 2 battery cover lock strikers.

Hint

Align the protrusion and notch on the service plug grip with the battery cover lock strikers, and turn the button counterclockwise to release the strikers.

- (2) Using an insulated tool, remove the 8 bolts and No. 2 hybrid vehicle battery shield reinforcement.

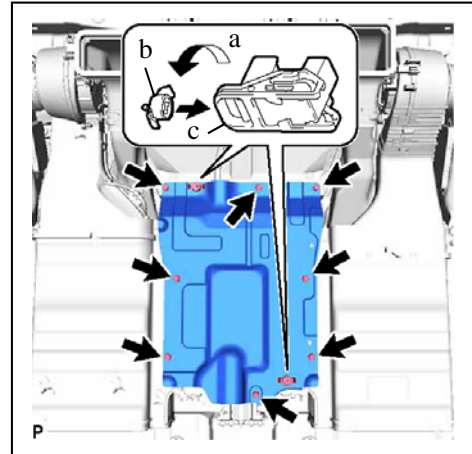

a	Counterclockwise
b	Notch
c	Protrusion

38. DISCONNECT POSITIVE AUXILIARY BATTERY TERMINAL

- (1) Remove the nut and disconnect the positive (+) auxiliary battery terminal.

Notice

Insulate the terminals of the removed auxiliary battery terminal with insulating tape.

- (2) Disconnect the 5 wire harness clamps and connector.

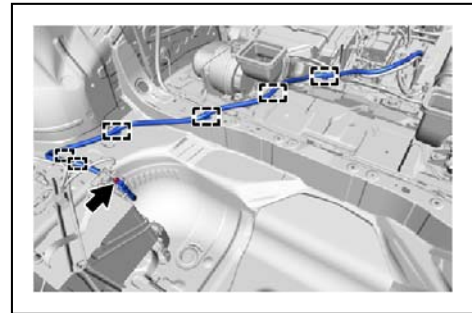

39. REMOVE AUXILIARY BATTERY

- (1) Remove battery clamp sub-assembly from the auxiliary battery.

i. for Type A:

Remove the bolt, 3 nuts and battery clamp sub-assembly from the auxiliary battery.

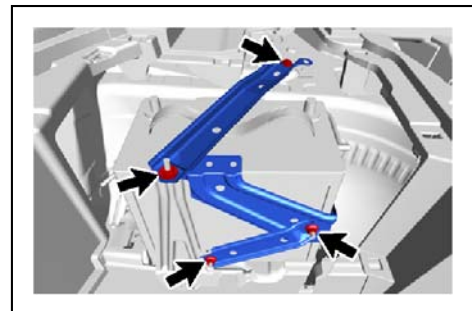

ii. for Type B:

Remove the bolt, nut and battery clamp sub-assembly from the auxiliary battery.

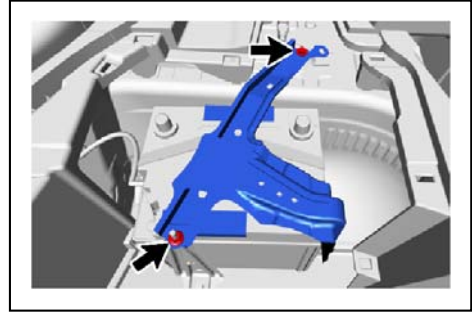

- (2) Disconnect the auxiliary battery hose.
- (3) Remove the battery insulator from the auxiliary battery.
- (4) Remove the auxiliary battery.

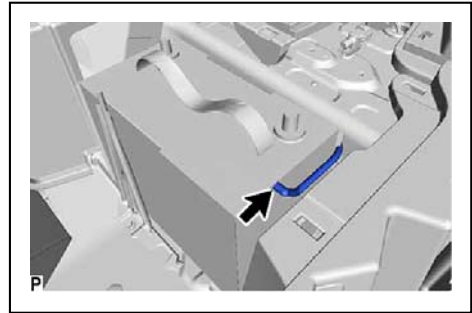

40. DISCONNECT WIRE HARNESS

Caution

Wear insulated gloves and use insulated tools.

Notice:

- To prevent the wire harness from being caught, make sure to bundle the wire harness using insulating tape or equivalent.
- Insulate the removed terminals and connector with insulating tape.

- (1) Disconnect the connector and wire harness clamp from the battery cooling blower assembly LH.
- (2) Disconnect the connector and wire harness clamp from the battery cooling blower assembly RH.

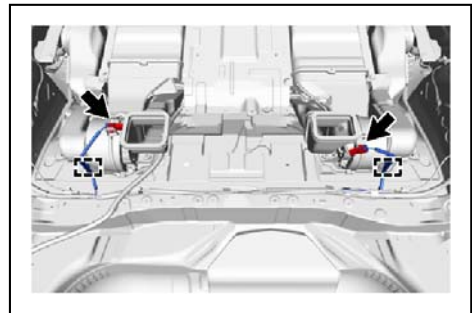

- (3) Disconnect the 2 connectors and 6 wire harnessclamps.

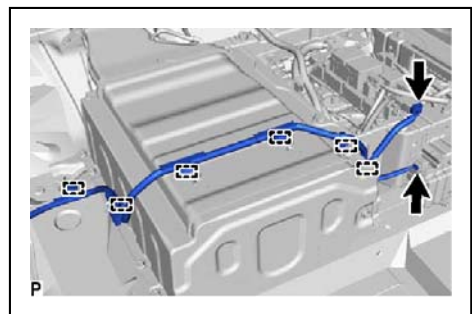

- (4) Using an insulated tool, remove the 3 nuts, and disconnect the 2 No. 2 frame wires (high-voltage cables) and ground terminal.

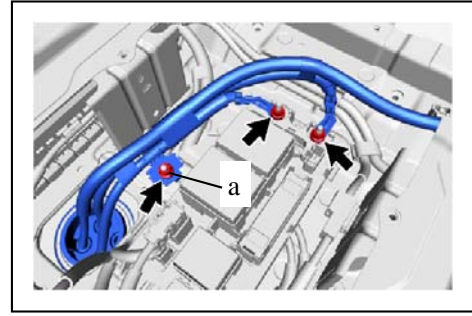

a	Ground Terminal
---	-----------------

41. REMOVE HV BATTERY ASSEMBLY

Caution

Be sure to wear insulated gloves and protective goggles.

- (1) Use cardboard or other similar material to protect the HV battery assembly and vehicle body from damage.
- (2) Remove the 6 bolts, 2 ground bolts, 2 nuts and HV battery assembly.

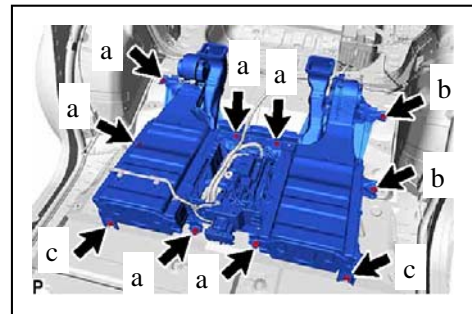

a	Bolt
b	Ground Bolt
c	Nut

- (3) Lift up the HV battery assembly, and pull out the 3 cables from the HV battery assembly towards the lower side.

Notice:

- Hold the areas shown in the illustration and lift up the HV battery assembly.
- Since the HV battery assembly is very heavy, 4 people are needed to remove the HV battery assembly.

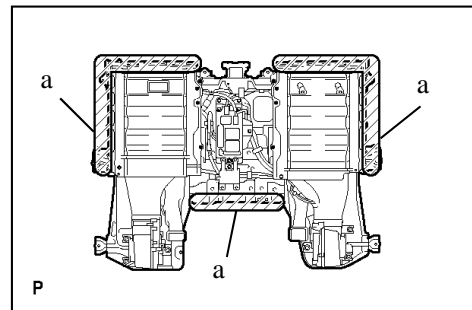

a	Areas to be Held
---	------------------

(4) Remove the HV battery assembly from the vehicle.

Notice:

- Since the HV battery assembly is very heavy, 4 people are needed to remove the HV battery assembly.
- To prevent the wire harness from being caught, make sure to bundle the wire harness using insulating tape or equivalent.
- When removing / installing / moving the HV battery assembly, make sure not to tilt it more than 80°.

Hint:

When removing and installing the HV battery, do so from the back door opening.

(5) Place the HV battery assembly on attachments.

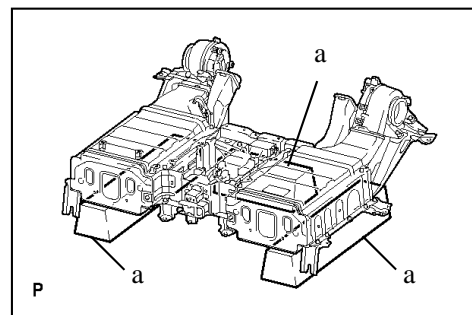

a	Attachment
---	------------