

 **TOYOTA**
PRIUS

Plug-in Hybrid

Gasoline-Electric

Hybrid Synergy Drive

HYBRID VEHICLE
DISMANTLING
MANUAL



Foreword

This guide was developed to educate and assist dismantlers in the safe handling of Toyota Prius Plug-in gasoline-electric hybrid vehicles. Prius Plug-in hybrid dismantling procedures are similar to other non-hybrid Toyota vehicles with the exception of the high voltage electrical system. It is important to recognize and understand the high voltage electrical system features and specifications of the Toyota Prius Plug-in hybrid, as they may not be familiar to dismantlers.

High voltage electricity powers the A/C compressor, electric motor, generator, and inverter/converter. All other conventional automotive electrical devices such as the headlights, radio, and gauges are powered from a separate 12 Volt auxiliary battery. Numerous safeguards have been designed into the Prius Plug-in hybrid to help ensure the high voltage, approximately 346 Volt, Lithium-ion (Li-ion) Hybrid Vehicle (HV) battery pack is kept safe and secure in an accident.

The Li-ion HV battery pack contains sealed batteries that are similar to rechargeable batteries used in some battery operated power tools and other consumer products. The electrolyte is absorbed in the cell plates and will not normally leak out even if the battery is cracked. In the unlikely event the electrolyte does leak, it can be easily neutralized with a dilute boric acid solution or vinegar.

High voltage cables, identifiable by orange insulation and connectors, are isolated from the metal chassis of the vehicle.

Additional topics contained in the guide include:

- Toyota Prius Plug-in hybrid identification.
- Major hybrid component locations and descriptions.

By following the information in this guide, dismantlers will be able to handle Prius Plug-in hybrid-electric vehicles as safely as the dismantling of a conventional non-hybrid automobile.

© 2010 Toyota Motor Corporation

All rights reserved. This book may not be reproduced or copied, in whole or in part, without the written permission of Toyota Motor Corporation.

Table of Contents

| | |
|--|------------------|
| <u>About the Prius Plug-in hybrid</u> | <u>1</u> |
| <u>Prius Plug-in hybrid Identification</u> | <u>2</u> |
| Exterior | 3 |
| <u>Prius Plug-in hybrid Identification (Continued)</u> | <u>4</u> |
| Interior..... | 4 |
| Engine Compartment | 5 |
| <u>Hybrid Component Locations & Descriptions</u> | <u>6</u> |
| Specifications | 7 |
| <u>Hybrid Synergy Drive Operation</u> | <u>8</u> |
| Vehicle Operation..... | 8 |
| <u>Hybrid Vehicle (HV) Battery Pack and Auxiliary Battery</u> | <u>9</u> |
| HV Battery Pack..... | 9 |
| Components Powered by the HV Battery Pack..... | 9 |
| HV Battery Pack Recycling | 10 |
| Auxiliary Battery | 10 |
| <u>High Voltage Safety</u> | <u>11</u> |
| High Voltage Safety System..... | 11 |
| Service Plug Grip | 12 |
| <u>Precaution to be observed when dismantling the vehicle</u> | <u>13</u> |
| Necessary Items | 13 |
| <u>Spills</u> | <u>14</u> |
| <u>Dismantling the vehicle</u> | <u>15</u> |
| <u>Removal of HV battery</u> | <u>19</u> |
| HV Battery Caution Label | 34 |

About the Prius Plug-in hybrid

The Prius Plug-in hybrid contains a gasoline engine, an electric motor, and a newly developed large capacity Li-ion battery. It is the first Toyota hybrid that allows the HV battery to be plugged-in and charged by an external power source. Two power sources are stored on board the vehicle:

1. Gasoline stored in the fuel tank for the gasoline engine.
2. Electricity stored in a large capacity externally chargeable high voltage Hybrid Vehicle (HV) battery assembly for the electric motor.

Depending on the driving conditions, one or both sources are used to power the vehicle. The following illustration demonstrates how the Prius Plug-in hybrid operates in various driving modes.

Plug-in EV (Electric Vehicle) Mode:

- ❶ Utilizing the charge cable assembly connected to a 120 Volt outlet, the vehicle's HV battery can be charged within 4 hours.
- ❷ When the HV battery is sufficiently charged, the vehicle will basically run on the power of the motor.
- ❸ If the vehicle exceeds 100 km/h or accelerates suddenly when traveling in plug-in EV mode, the gasoline engine and motor work together to power the vehicle.

HV (Hybrid Vehicle) Mode:

- ❹ During light acceleration at low speeds, the vehicle is powered by the electric motor. The gasoline engine is shut off.
- ❺ During normal driving, the vehicle is powered mainly by the gasoline engine. The gasoline engine also powers the generator to recharge the battery assembly.
- ❻ During full acceleration, such as climbing a hill, both the gasoline engine and the electric motor power the vehicle.
- ❼ During deceleration, such as when braking, the vehicle regenerates the kinetic energy from the front wheels to produce electricity that recharges the battery assembly.
- ❽ While the vehicle is stopped, the gasoline engine and electric motor are off, however the vehicle remains on and operational.

❶ Plug-in Charging ❷ Normal Driving ❸ Hard Acceleration

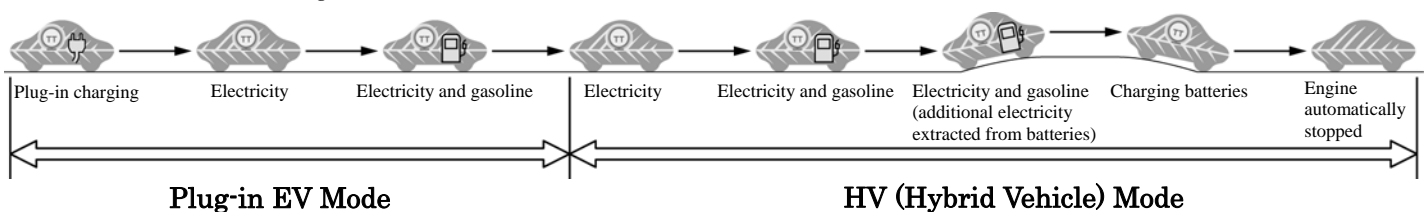

Prius Plug-in hybrid Identification

In appearance, the 2010 model year Prius Plug-in hybrid is a 5-door hatchback. Exterior, interior, and engine compartment illustrations are provided to assist in identification.

The alphanumeric 17 character Vehicle Identification Number (VIN) is provided in the front windshield cowl and on the left side door pillar.

Example VIN: **JTDKN3DPA82020211** or **JTDKN36PA82020211**

A Prius Plug-in hybrid is identified by the first 8 alphanumeric characters **JTDKN3DP** or **JTDKN36P**.

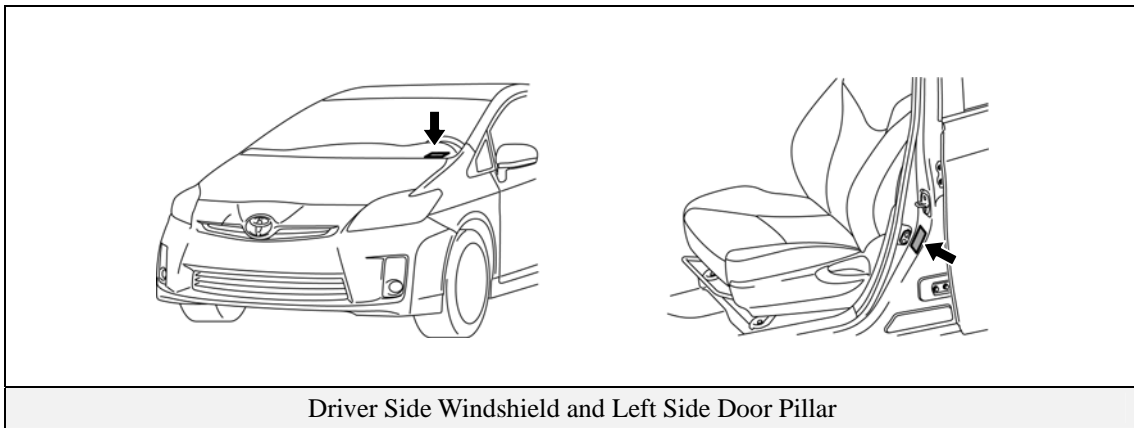

Prius Plug-in hybrid Identification (Continued)

Exterior

❶  logo on the front right fender.

❷ Charge inlet door with  logo, located on driver side front fender.

❸ Plug-in Hybrid decals located on the sides of the vehicle.

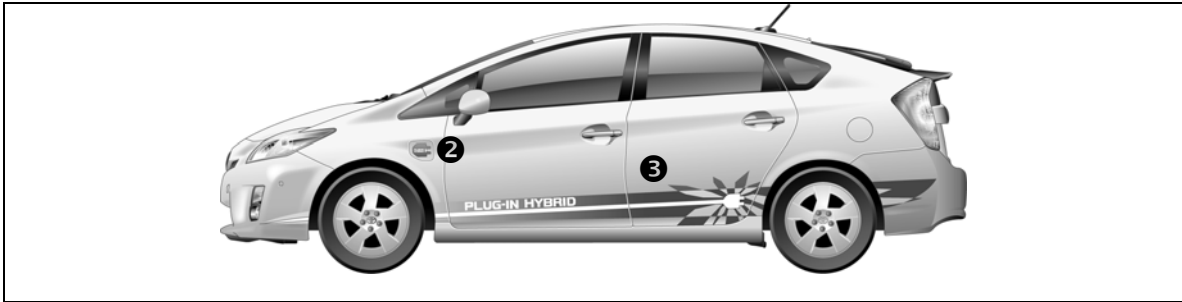

Exterior Driver Side View

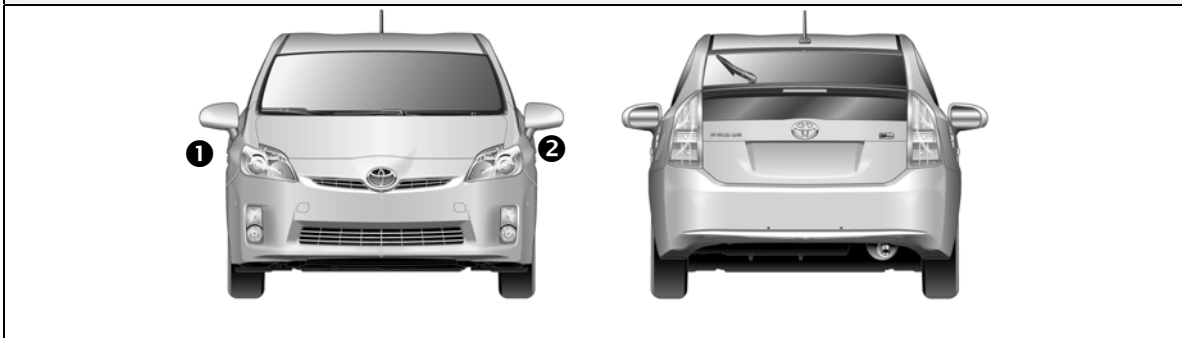

Exterior Front and Rear View



Exterior Rear and Driver Side View

Prius Plug-in hybrid Identification (Continued)

Interior

- ④ Instrument cluster (speedometer, **READY** light, shift position indicators, warning lights) located in center of the dash and near the base of the windshield.

Hint:

If the vehicle is shut off, the instrument cluster gauges will be “blacked out”, not illuminated.

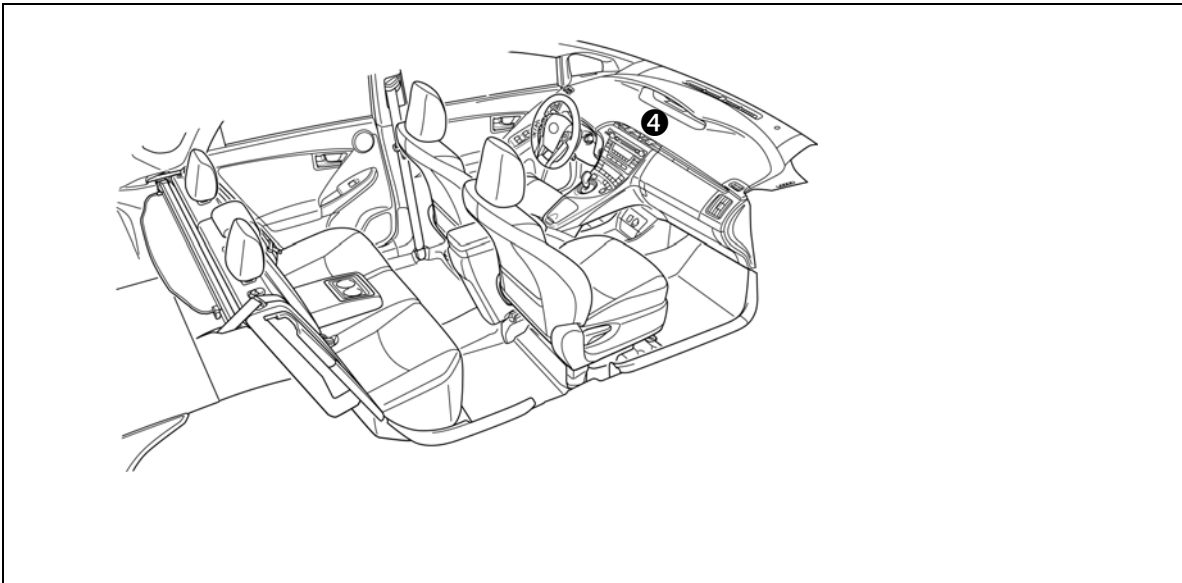

Interior View

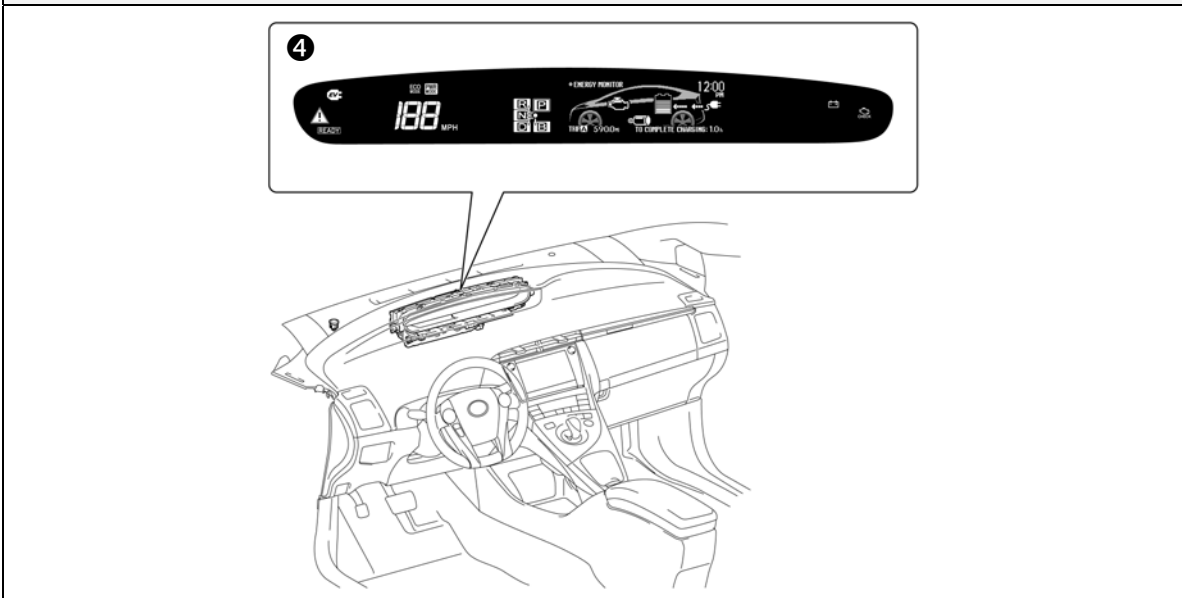

Instrument Cluster View

Prius Plug-in hybrid Identification (Continued)

Engine Compartment

- ⑤ 1.8-liter aluminum alloy gasoline engine.
- ⑥ Logo on the plastic engine cover.
- ⑦ Orange colored high voltage power cables.

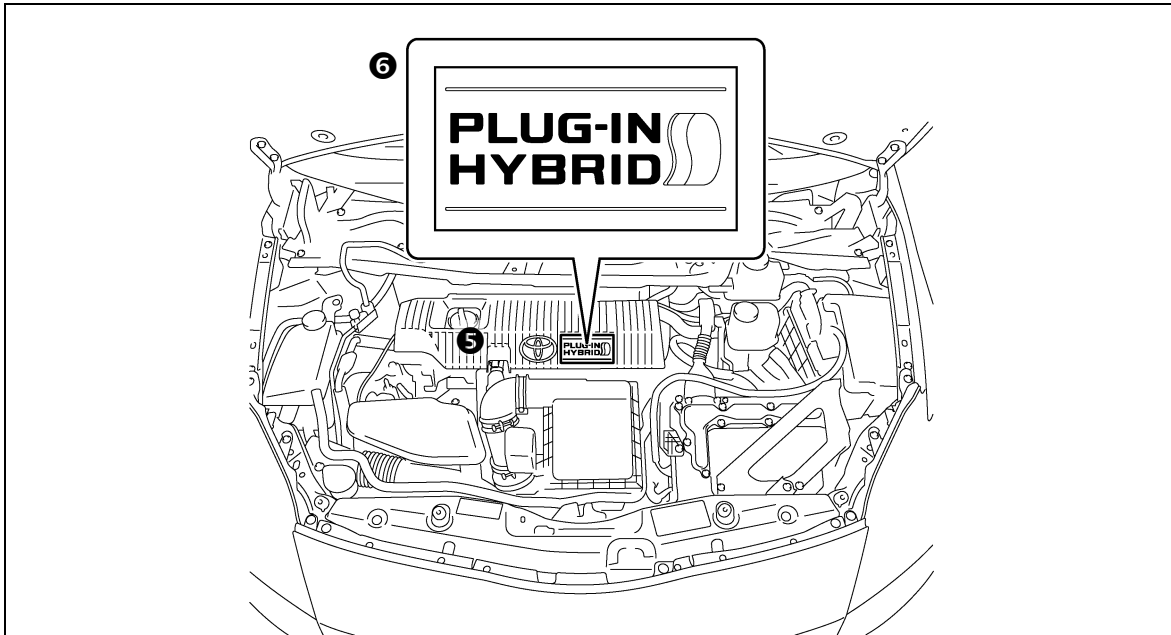

Engine Compartment View

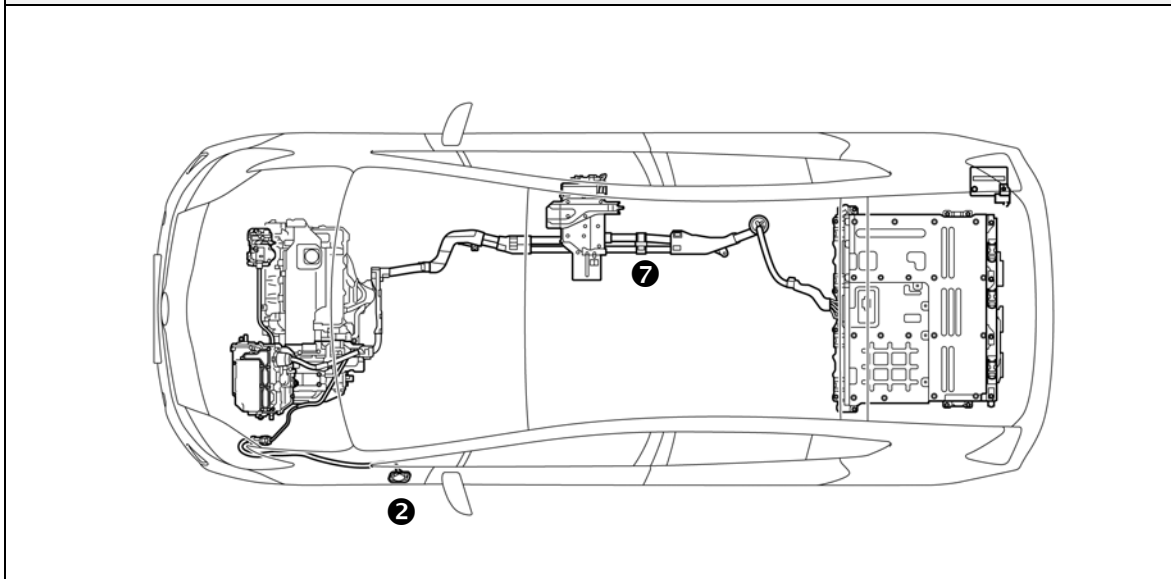

Power Cables

Hybrid Component Locations & Descriptions

| Component | Location | Description |
|--|--------------------------------------|--|
| 12 Volt ❶ Auxiliary Battery | Right Side of Cargo Area | A lead-acid battery that supplies power to the low voltage devices. |
| Hybrid ❷ Vehicle (HV) Battery Assembly | Cargo Area | 346 Volt Lithium-ion (Li-ion) battery pack consisting of 3.6 Volt cells connected in a series-parallel circuit. |
| Power ❸ Cables | Undercarriage and Engine Compartment | Orange colored power cables carry high voltage Direct Current (DC) between the HV battery assembly, inverter/converter, and A/C compressor. These cables also carry 3-phase Alternating Current (AC) between the inverter/converter, electric motor, and generator. |
| Inverter/Converter ❹ | Engine Compartment | Boosts and inverts the high voltage electricity from the HV battery assembly to 3-phase AC electricity that drives the electric motor. The inverter/converter also converts AC electricity from the electric generator and electric motor (regenerative braking) to DC that charges the HV battery assembly. |
| Gasoline ❺ Engine | Engine Compartment | Provides two functions: 1) Powers vehicle. 2) Powers generator to charge the HV battery assembly. The engine is started and stopped under control of the vehicle computer. |
| Electric ❻ Motor | Engine Compartment | 3-phase high voltage AC permanent magnet electric motor contained in the front transaxle. It is used to power the front wheels. |
| Electric ❼ Generator | Engine Compartment | 3-phase high voltage AC generator that is contained in the transaxle and charges the HV battery assembly. |

*Numbers in the component column apply to the illustrations on the following page.

Hybrid Component Locations & Descriptions (Continued)

Specifications

- Gasoline Engine: 98 hp (73 kW), 1.8-liter Aluminum Alloy Engine
- Electric Motors: 80 hp (60 kW), Permanent Magnet Motor
- Transmission: Automatic Only (electrically controlled continuously variable transaxle)
- HV Battery: 346 Volt Sealed Li-ion-Battery
- Curb Weight: 3,362 lbs/1,525 kg
- Fuel Tank: 11.9 gals/45.0 liters
- Frame Material: Steel Unibody
- Body Material: Steel Panels except for Aluminum Hood and Back Door
- Seating Capacity: 5 standard

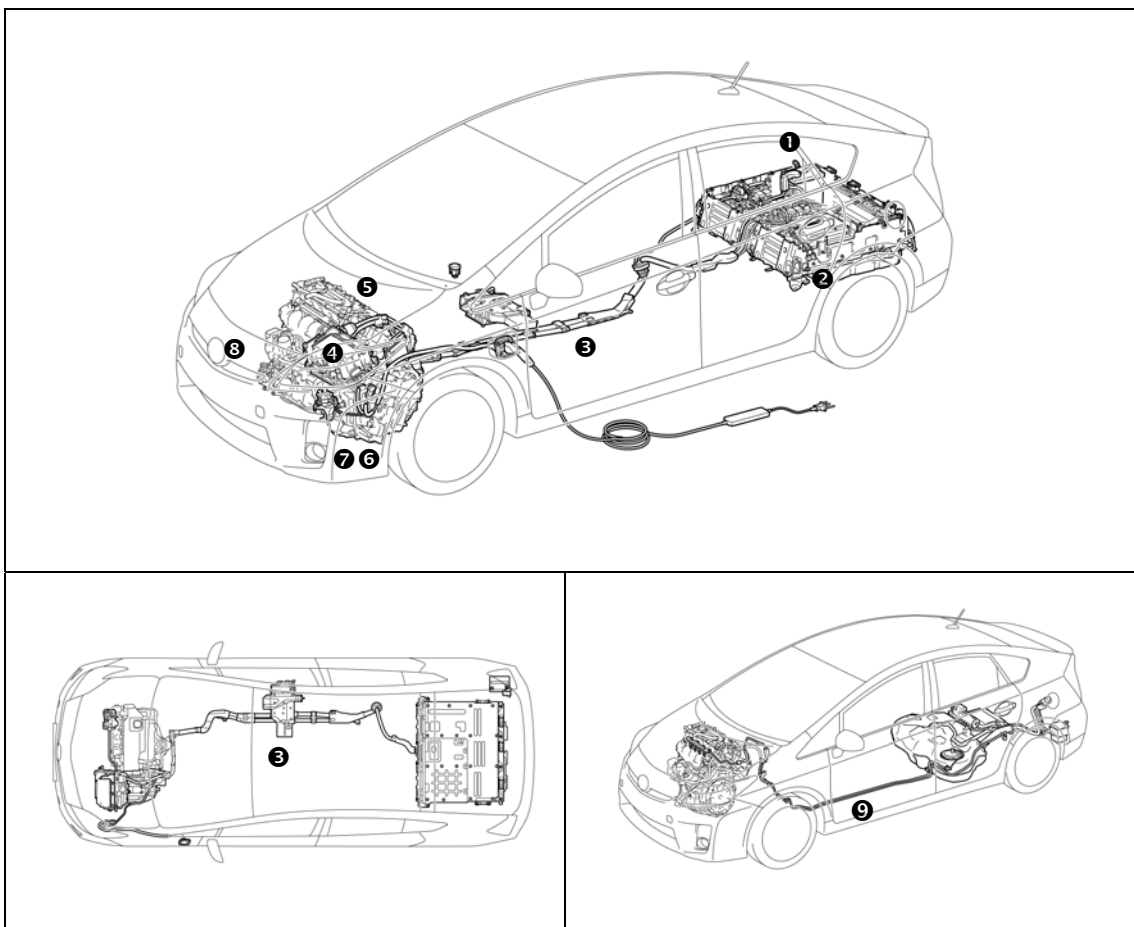

Hybrid Synergy Drive Operation

Once the **READY** indicator is illuminated in the instrument cluster, the vehicle may be driven. However, the gasoline engine does not idle like a typical automobile and will start and stop automatically. It is important to recognize and understand the **READY** indicator provided in the instrument cluster. When illuminated, it informs the driver that the vehicle is on and operational even though the gasoline engine may be off and the engine compartment is silent.

Vehicle Operation

- With the Prius Plug-in hybrid, the gasoline engine may stop and start at any time while the **READY** indicator is on.
- Never assume that the vehicle is shut off just because the engine is off. Always look for the **READY** indicator status. The vehicle is shut off when the **READY** indicator is off.

The vehicle may be powered by:

1. The electric motor only.
2. The gasoline engine only.
3. A combination of both the electric motor and the gasoline engine.

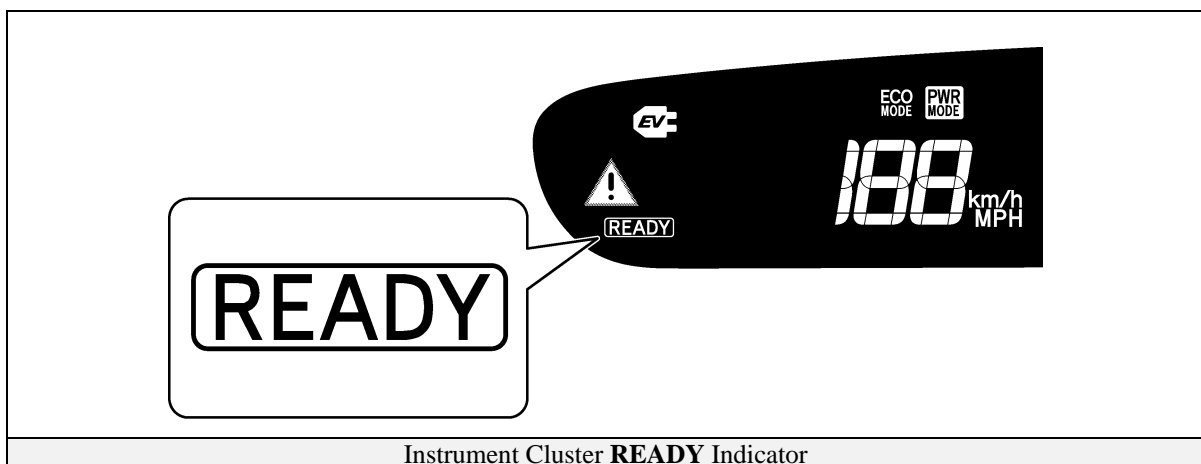

Hybrid Vehicle (HV) Battery Pack and Auxiliary Battery

The Prius Plug-in hybrid features a high voltage Hybrid Vehicle (HV) battery pack that contains sealed Lithium-ion (Li-ion) battery cells.

HV Battery Pack

- The HV battery pack is enclosed in a metal case and is rigidly mounted to the cargo area floor pan cross member behind the rear seat. The metal case is isolated from high voltage and concealed by carpet in the cabin area.
- The HV battery pack consists of 96 low voltage (3.6 Volt) Li-ion battery cells connected in series to produce approximately 346 Volts. Each Li-ion battery cell is non-spillable and in a sealed case.
- The electrolyte used in the Li-ion battery cell is an organic solvent containing lithium-ion. The electrolyte is absorbed into the electrode and will not normally leak, even in a collision.
- In the unlikely event that the battery pack is overcharged, the cells vent gases directly outside the vehicle through a vent hose.

| HV Battery Assembly | |
|---|--|
| Battery assembly voltage | 346 V |
| Number of Li-ion battery cells in the battery | 288 cells |
| Li-ion battery cell voltage | 3.6 V |
| Li-ion battery cell dimensions | 4.42 x 4.35 x 0.56 in. (112.2 x 110.6 x 14.1 mm) |
| Li-ion cell weight | 0.54 lbs (245 g) |
| Li-ion battery assembly dimensions | 32.4 x 38.1 x 14.9 in. (822.4 x 967.8 x 378.4 mm) |
| Li-ion battery assembly weight | 333 lbs (151.1 kg) |

Components Powered by the HV Battery Pack

- Electric Motor
- Power Cables
- Electric Generator
- Inverter/Converter Motor
- A/C Compressor

Hybrid Vehicle (HV) Battery Pack and Auxiliary Battery (Continued)

HV Battery Pack Recycling

- The HV battery pack is recyclable. Contact either your Toyota Distributor as mentioned on HV battery Caution Label (see page 35) or the nearest Toyota dealer.

Auxiliary Battery

- The Prius Plug-in hybrid also contains a lead-acid 12 Volt battery. This 12 Volt auxiliary battery powers the vehicle electrical system similar to a conventional vehicle. As with other conventional vehicles, the auxiliary battery is grounded to the metal chassis of the vehicle.
- The auxiliary battery is located in the cargo area. It is concealed by a fabric cover on the passenger side in the rear quarter panel well.

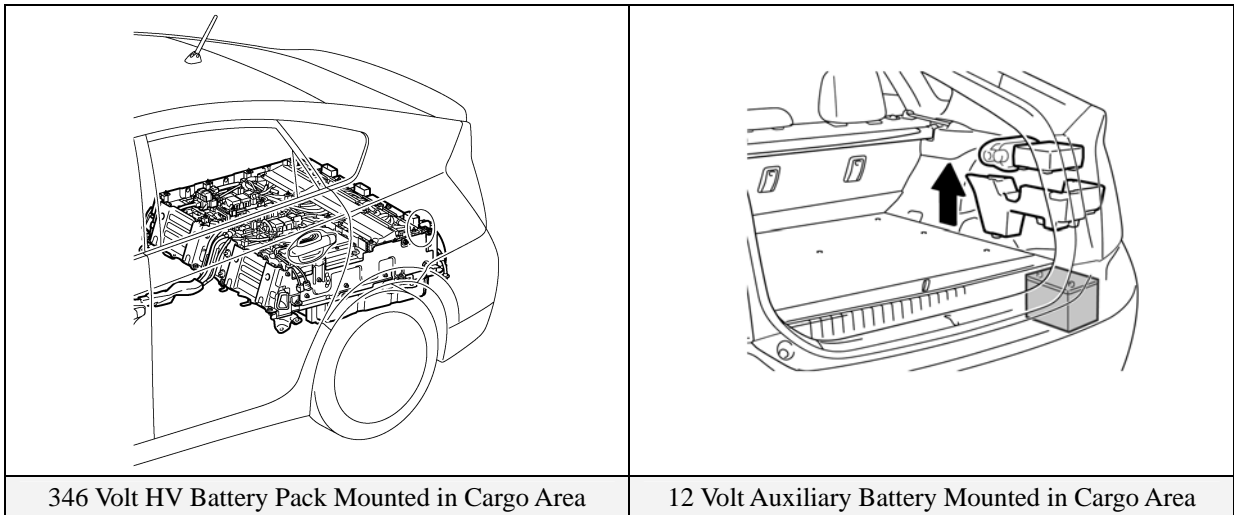

High Voltage Safety

The HV battery pack powers the high voltage electrical system with DC electricity. Positive and negative orange colored high voltage power cables are routed from the battery pack, under the vehicle floor pan, to the inverter/converter. The inverter/converter contains a circuit that boosts the HV battery voltage from 346 to 650 Volts DC. The inverter/converter creates 3-phase AC to power the motors. Power cables are routed from the inverter/converter to each high voltage motor (electric motor, electric generator, and A/C compressor). The following systems are intended to help keep occupants in the vehicle and emergency responders safe from high voltage electricity:

High Voltage Safety System

- A high voltage fuse ❶* provides short circuit protection in the HV battery pack.
- Positive and negative high voltage power cables ❷* connected to the HV battery pack are controlled by 12 Volt normally open relays ❸*. When the vehicle is shut off, the relays stop electricity flow from leaving the HV battery pack.



WARNING:

- ❹ ***The high voltage system may remain powered for up to 10 minutes after the vehicle is shut off or disabled. To prevent serious injury or death from severe burns or electric shock, avoid touching, cutting, or opening any orange high voltage power cable or high voltage component.***

- Both positive and negative power cables ❷* are insulated from the metal chassis, so there is no possibility of electric shock when touching the metal chassis.
- A ground-fault monitor continuously monitors for high voltage leakage to the metal chassis while the vehicle is running. If a malfunction is detected, the hybrid vehicle computer ❹* will illuminate the master warning light  in the instrument cluster and indicate “CHECK HYBRID SYSTEM” on the multi-information display.
- The HV battery pack relays will automatically open to stop electricity flow in a collision sufficient to activate the SRS.

*Numbers apply to the illustration on the following page.

High Voltage Safety (Continued)

Service Plug Grip

- The high-voltage circuit is cut by removing the service plug grip (see page 16).

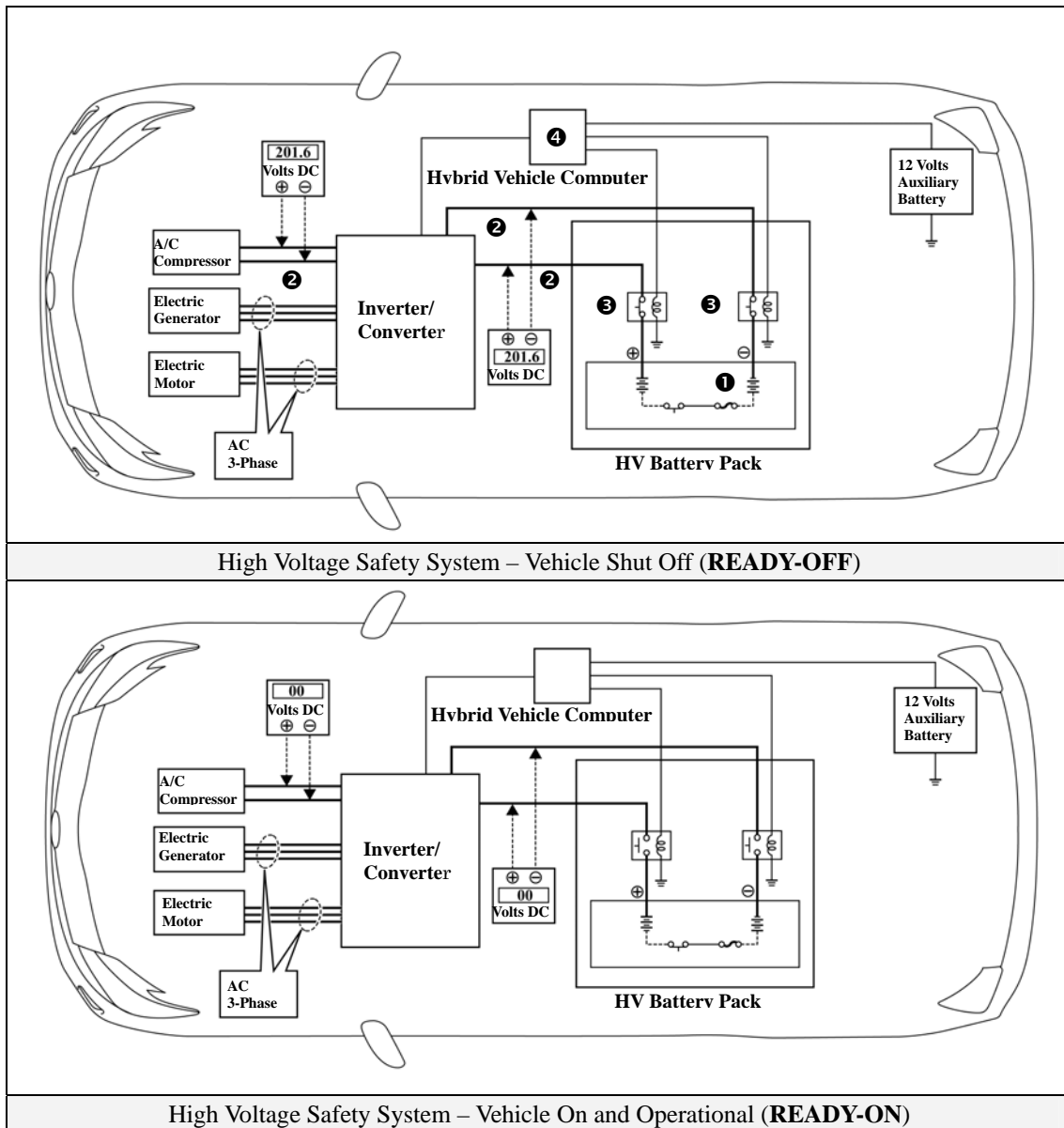

Precaution to be observed when dismantling the vehicle



WARNING:

- ⑥ *The high voltage system may remain powered for up to 10 minutes after the vehicle is shut off or disabled. To prevent serious injury or death from severe burns or electric shock, avoid touching, cutting, or opening any orange high voltage power cable or high voltage component.*

Necessary Items

- Protective clothing such as insulated gloves (electrically insulated), rubber gloves, safety goggles, and safety shoes.
- Insulating tape such as electrical tape that has a suitable electrical insulation rating.
- Before wearing insulated gloves, make sure that they are not cracked, ruptured, torn, or damaged in any way. Do not wear wet insulated gloves.
- An electrical tester that is capable of measuring DC 750 Volts or more.

Spills

The Prius Plug-in hybrid contains the same common automotive fluids used in other non-hybrid Toyota vehicles, with the exception of the Li-ion electrolyte used in the HV battery assembly. The electrolyte used in the Li-ion battery cells is a flammable organic electrolyte containing carbonic acid esters. As the electrolyte is absorbed into the electrode, even if the battery cells crack, there is very little chance of liquid electrolyte leaking out. However, the electrolyte may react with moisture in the air and generate an acidic vapor. Some flammable gases may be produced as a byproduct.

NOTE:

Leakage of liquid electrolyte from the HV battery assembly is extremely unlikely due to its construction and the amount of available electrolyte contained within the Li-ion cells. Any liquid electrolyte that leaks from a Li-ion battery cell quickly evaporates. Any spillage would not warrant a declaration as a hazardous material incident. Responders should follow the recommendations as outlined in this emergency response guide.

- Handle Li-ion electrolyte spills using the following Personal Protective Equipment (PPE):
 - Splash shield or safety goggles. Fold down helmet shields are not acceptable for acid or electrolyte spills.
 - Rubber gloves.
 - Apron suitable for acid.
 - Rubber boots.
 - SCBA

Dismantling the vehicle

The following 2 pages contain general instructions for use when working on a Prius Plug-in hybrid. Read these instructions before proceeding to the HV battery removal instructions on page 19.



WARNING:

- ⑥ ***The high voltage system may remain powered for up to 10 minutes after the vehicle is shut off or disabled. To prevent serious injury or death from severe burns or electric shock, avoid touching, cutting, or opening any orange high voltage power cable or any high voltage component.***

1. Shut off the ignition (**READY** indicator is off).
Then disconnect the cable from the auxiliary battery negative (-) terminal.
 - (1) Remove the auxiliary battery cover.
 - (2) Remove the tire repair kit and styrofoam insert.
 - (3) Disconnect the battery negative terminal.

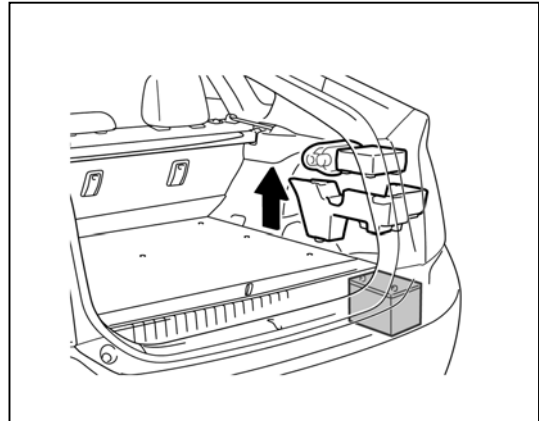

2. Remove the 3 service plug grips.

Caution:

Wear insulated gloves for the following 3 steps.

- (1) Slide the handle of the service plug grip to the right.
- (2) Raise the release handle of the service plug grip
- (3) Remove the service plug grip.
- (4) Apply insulating tape to the socket of the service plug grip to insulate it.

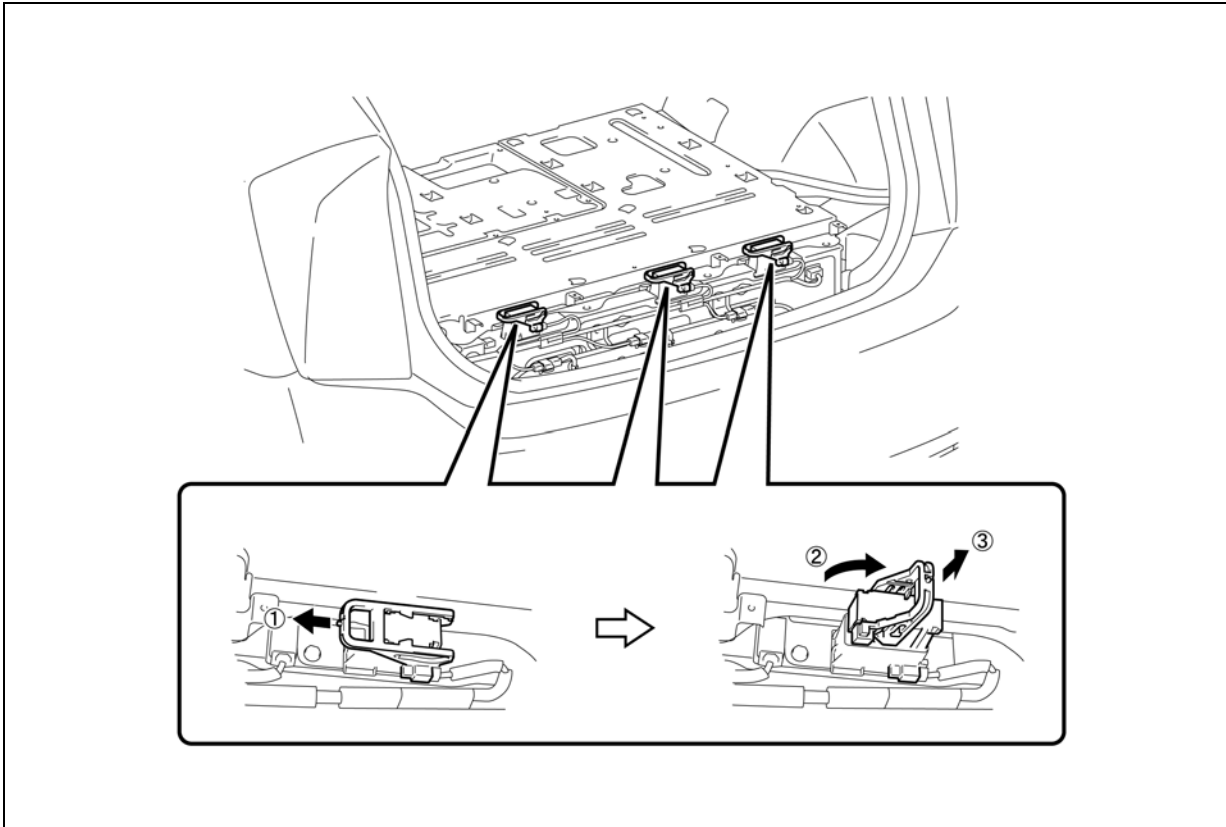

3. Carry the removed service plug grip in your pocket to prevent other staff from accidentally reinstalling it while you are dismantling the vehicle.
4. Make other staff aware that a high-voltage system is being dismantled by using the following sign: CAUTION: HIGH-VOLTAGE. DO NOT TOUCH (see page 18).
5. If the service plug grip cannot be removed due to damage to the vehicle, remove the **IGCT** fuse (30A) and **AM2** fuse (7.5A).

Caution:

This operation shuts off the HV system. Be sure to wear insulated gloves because high voltage is not shut off inside the HV battery. When it is possible to remove the service plug grip, remove it and continue the procedure.

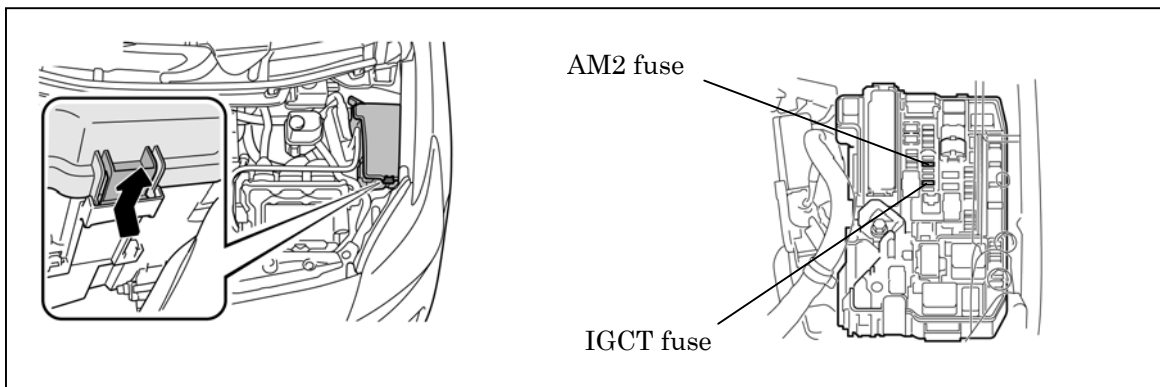

6. After disconnecting or exposing a high-voltage connector or terminal, insulate it immediately using insulating tape. Before disconnecting or touching a bare high-voltage terminal, wear insulated gloves.
7. Check the HV battery and nearby area for leakage. If you find any liquid, it may be strong alkaline electrolyte. Wear rubber gloves and goggles and neutralize the liquid using a saturated boric acid solution or vinegar. Then wipe up the liquid using waste rags etc.
8. If the electrolyte comes into contact with your skin, wash the skin immediately using a saturated boric acid solution or a large amount of water. If the electrolyte adheres to any article of clothing, take the clothing off immediately.
9. If the electrolyte comes into contact with your eye(s), call out loudly for help. Do not rub your eye(s). Instead, wash the eye(s) with a dilute boric acid solution or a large amount of water and seek medical care.
10. With the exception of the HV battery, remove parts by following procedures which are similar to conventional Toyota vehicles. For the removal of the HV battery, refer to the following pages.

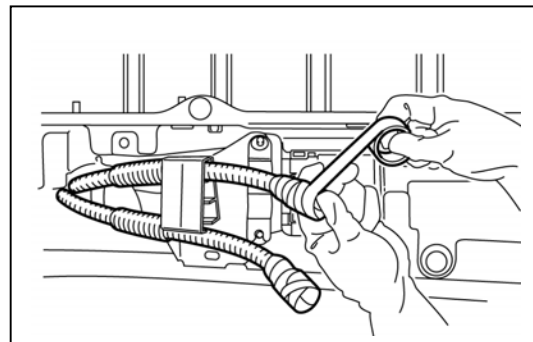

Person in charge: _____

CAUTION:
HIGH-VOLTAGE.
DO NOT TOUCH.

CAUTION:
HIGH-VOLTAGE.
DO NOT TOUCH.

Person in charge: _____

When performing work on the HV system, fold this sign and put it on the roof of the vehicle.

Removal of HV battery



WARNING:

- ⑥ ***Be sure to wear insulated gloves when handling high-voltage parts.***
- ⑥ ***Even if the vehicle is shut off and the relays are off, be sure to remove the service plug grip before performing any further work.***
- ⑥ ***Power remains in the high voltage electrical system for 10 minutes even after the HV battery pack is shut off because the circuit has a condenser that stores power.***
- ⑥ ***Make sure that the tester reading is 0 V before touching any high-voltage terminals which are not insulated.***
- ⑥ ***The SRS may remain powered for up to 90 seconds after the vehicle is shut off or disabled. To prevent serious injury or death from unintentional SRS deployment, avoid cutting the SRS components.***

1. Shut off the ignition (**READY** indicator is off).
2. Remove the tonneau cover assembly.
3. Remove the 12volt auxiliary battery.
 - (1) Remove the auxiliary battery cover.

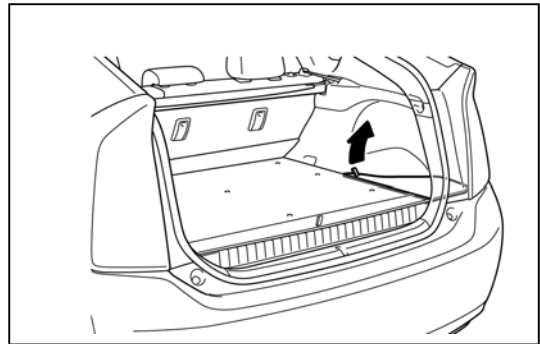

- (2) Remove the tire repair kit.
- (3) Remove the styrofoam insert.
- (4) Disconnect the cable from the auxiliary battery negative (-) terminal.
- (5) Disconnect the cable from the auxiliary battery positive (+) terminal.
- (6) Remove the 12volt auxiliary battery.

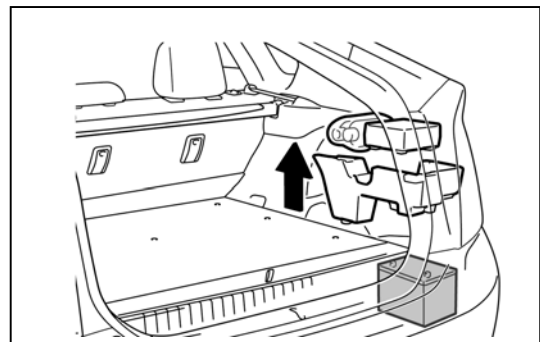

4. Remove the rear No. 4 floor board.

- (1) Using a clip remover, disengage the 3 clips and remove the rear No. 4 floor board.

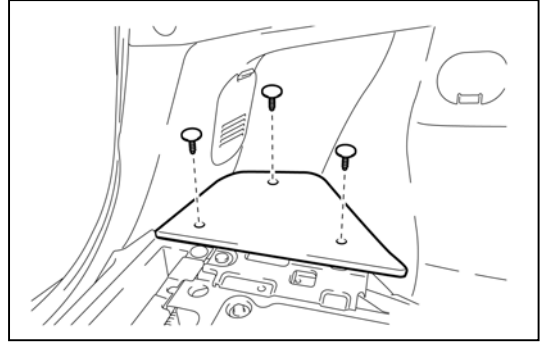

5. Remove the rear No. 1 floor board.

- (1) Using a clip remover, disengage the 8 clips.

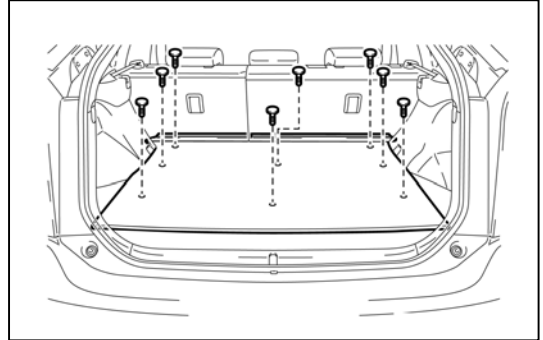

- (2) Disengage the 3 fasteners and disconnect the rear No. 1 floor board from the rear seat assembly LH.

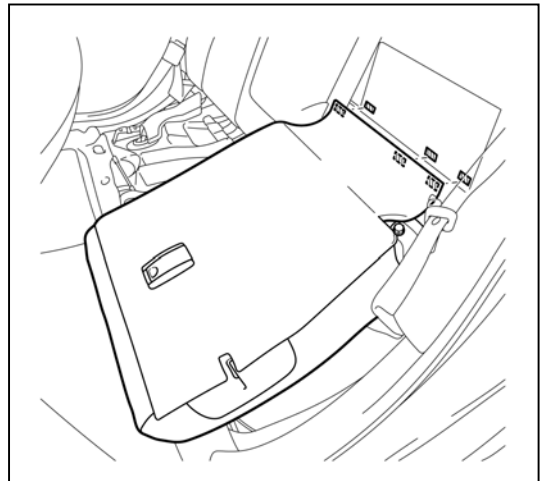

- (3) Disengage the 3 fasteners and disconnect the rear No. 1 floor board from the rear seat assembly RH and remove the rear No. 1 floor board.

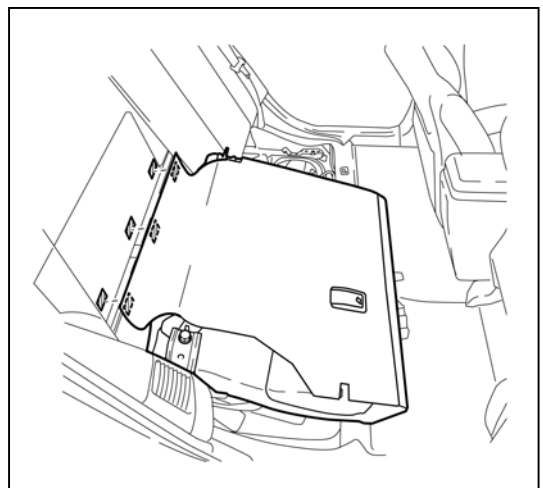

6. Remove the rear deck trim cover.

- (1) Remove the bolt.
- (2) Using a clip remover, disengage the 4 clips.
- (3) Disengage the 4 claws and 4 guides, and remove the rear deck trim cover.

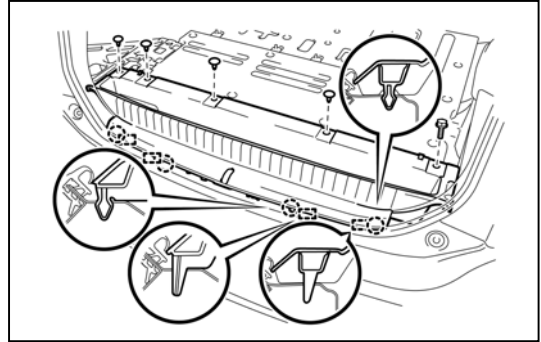

7. Remove the hybrid battery carrier bracket.

- (1) Remove the bolt.
- (2) Disengage the 2 pins and remove the hybrid battery carrier bracket.

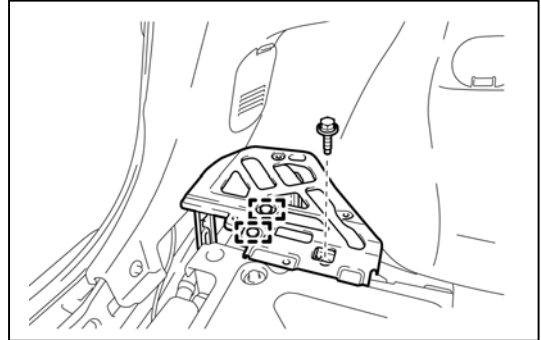

8. Remove the 3 service plug grips.

Caution:

- **Wear insulated gloves.**
- **Before inspecting or servicing the high-voltage system or disconnecting the low voltage connector of the inverter with converter assembly, be sure to follow all safety measures, such as wearing insulated gloves and removing the 3 service plug grips to prevent electrocution. After removing the 3 service plug grips, carry one of the 3 service plug grips in your pocket to prevent other technicians from accidentally reconnecting it while you are servicing the vehicle. Keep the other 2 service plug grips in a secure place.**
- **High voltage wiring connectors are colored in orange.**

- (1) Slide the handle of the service plug grip to the right.
- (2) Raise the release handle of the service plug grip as shown in the illustration below.
- (3) Remove the service plug grip.
- (4) Apply insulating tape to the socket of the service plug grip to insulate it.

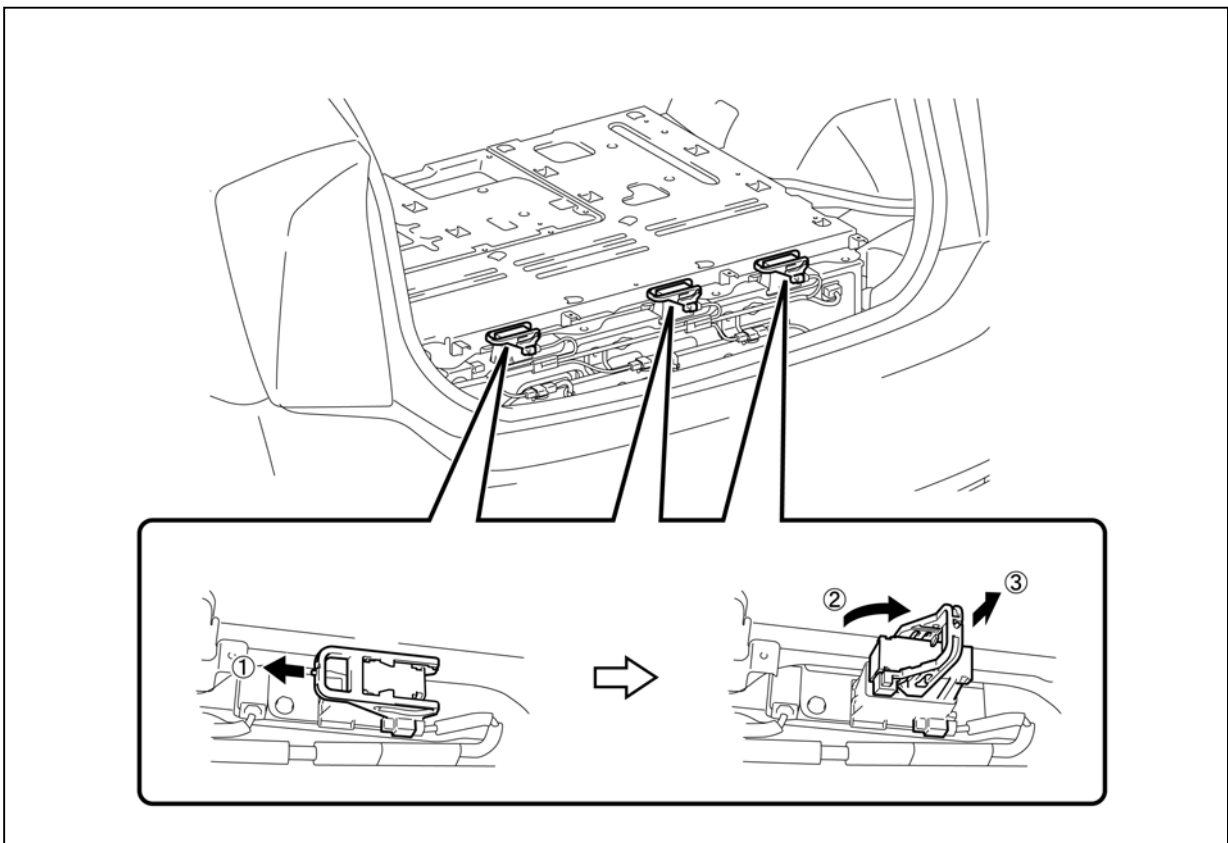

9. Remove the 9 bolts and inverter terminal cover.

Caution:

Wear insulated gloves.

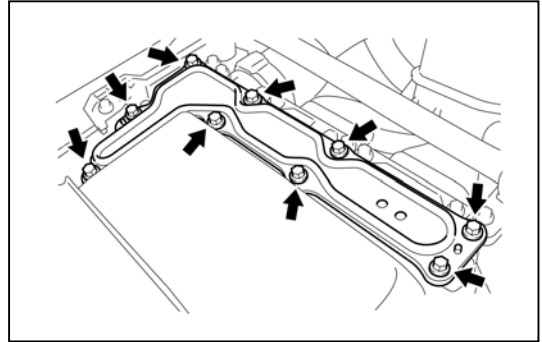

10. Check the voltage at the terminals in the inspection point in the power control unit.

Caution:

Wear insulated gloves.

To prevent serious injury or death, do not proceed with dismantling of the HV system until the voltage at the terminals in the inspection point is 0 V.

Standard voltage: 0 V

Hint:

Set the tester to DC 750 Volts measure the voltage.

This inspection is performed to verify that it is safe to remove the HV battery.

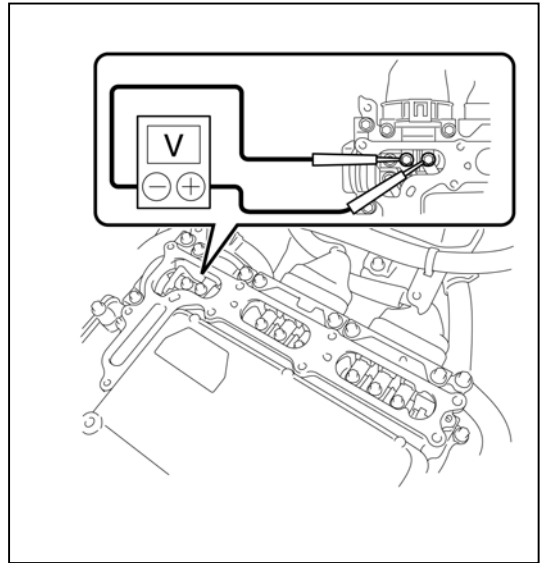

11. Cut the rear center seatbelt.

12. Remove the rear seat cushion assembly.

- (1) Disengage the 2 front hooks of the seat cushion from the vehicle body as shown in the illustration.
- (2) Disengage the 2 guides of the seat cushion from the seatback.
- (3) Remove the rear seat cushion assembly.

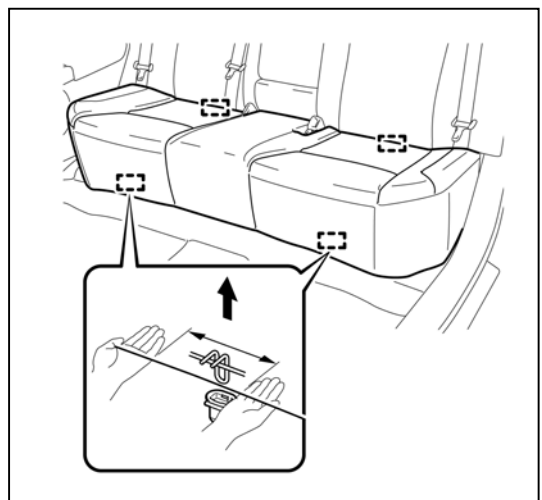

13. Remove the rear side seatback assembly RH.

(4) Remove the bolt.

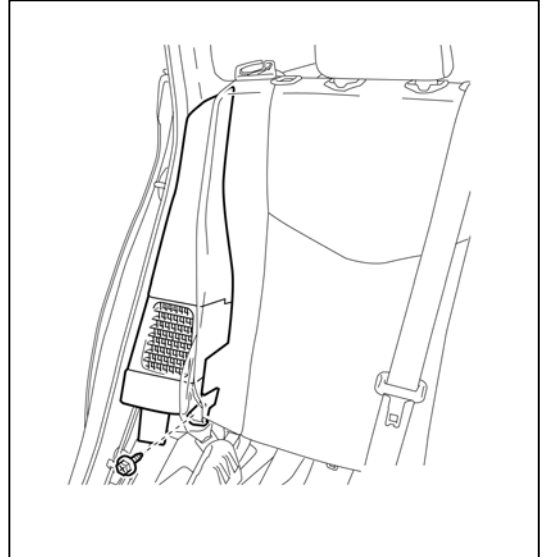

(5) Disengage the 2 guides and remove the rear side seatback assembly RH.

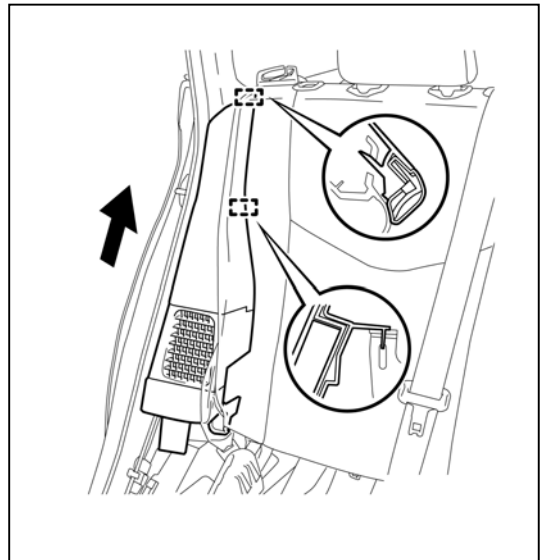

14. Remove the rear side seatback assembly LH.

(1) Remove the bolt.

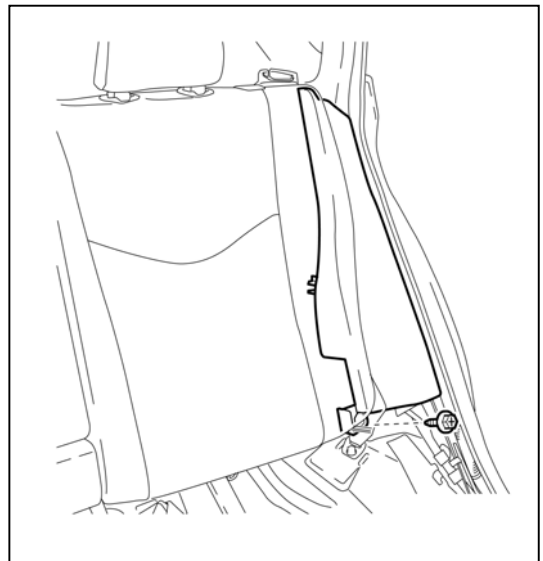

- (2) Disengage the 2 guides and remove the rear side seatback assembly LH.

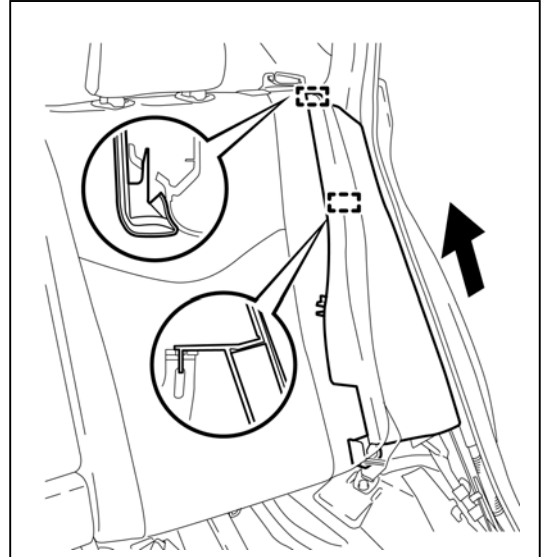

15. Disconnect the rear center seat belt assembly.

- (1) Remove the bolt and disconnect the anchor part of the rear center seat belt assembly.

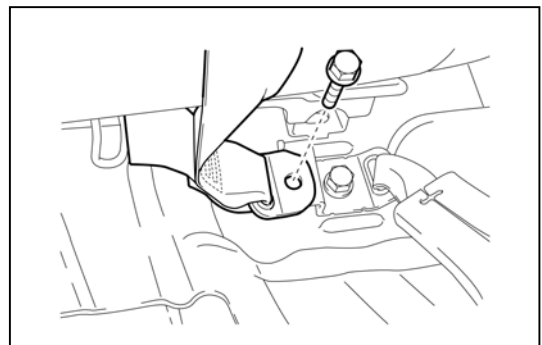

16. Remove the rear seatback assembly LH.

- (1) Remove the 2 bolts and rear seatback assembly LH.

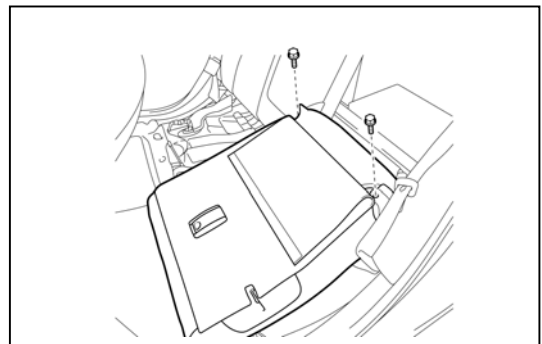

17. Remove the rear seatback assembly RH.

- (1) Remove the 2 bolts and rear seatback assembly RH.

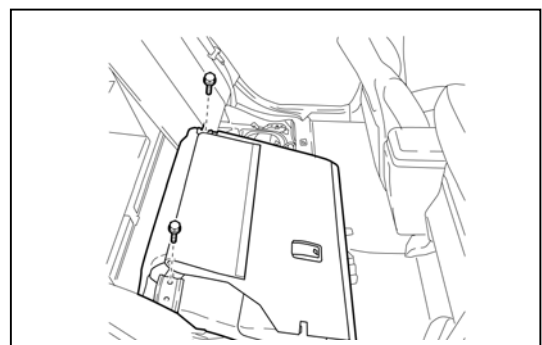

18. Remove the battery cooling blower bracket.

Notice:

- **Be sure not to touch the fan part of the battery cooling blower assemblies.**
- **Do not lift the battery cooling blower assemblies using the wire harness.**

(1) Disconnect the battery cooling blower assembly connectors.

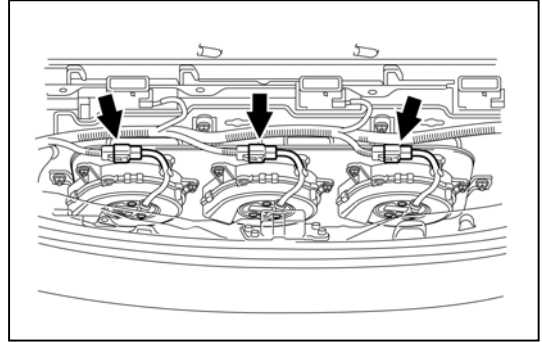

(2) Remove the 4 bolts and battery cooling blower bracket.

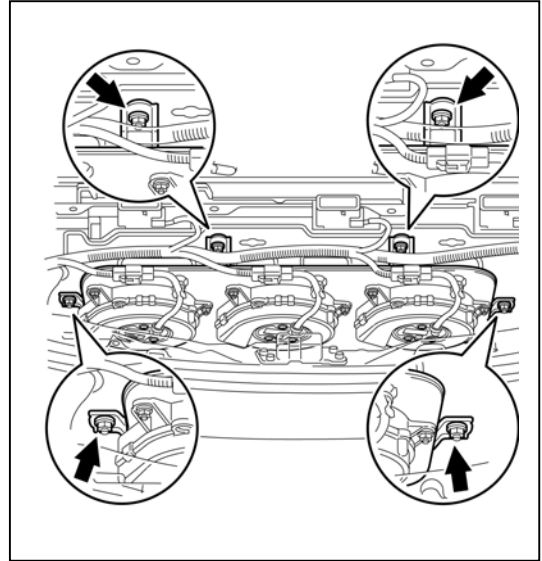

19. Remove the No. 5 hybrid battery intake duct.

(1) Remove the 2 clips and No. 5 hybrid battery intake duct (sub2).

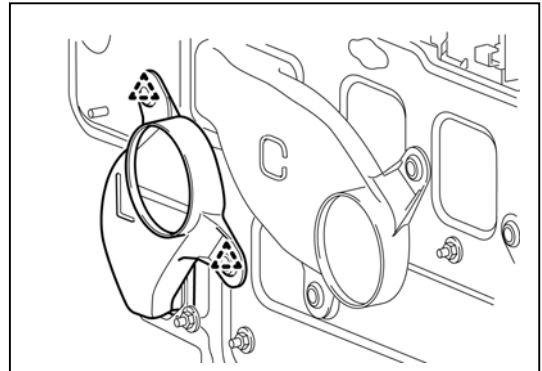

(2) Remove the 2 clips and No. 5 hybrid battery intake duct (sub1).

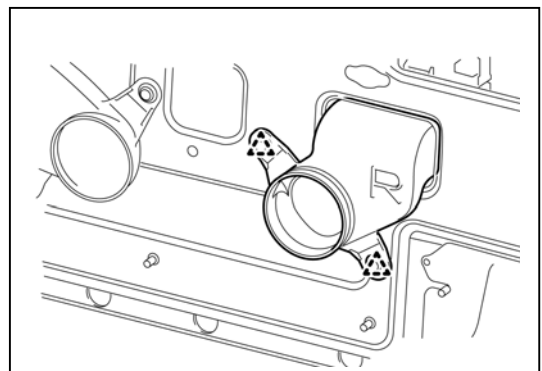

- (3) Remove the 2 clips and No. 5 hybrid battery intake duct (main).

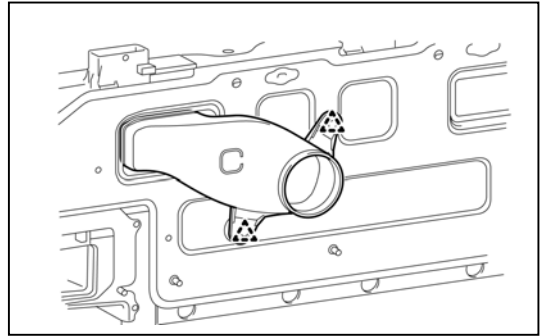

20. Remove the battery cooling blower assembly.

Notice:

- Be sure not to touch the fan part of the battery cooling blower assemblies.
- Do not lift the battery cooling blower assemblies using the wire harness.

- (1) Remove the 9 nuts and 3 battery cooling blower assemblies.

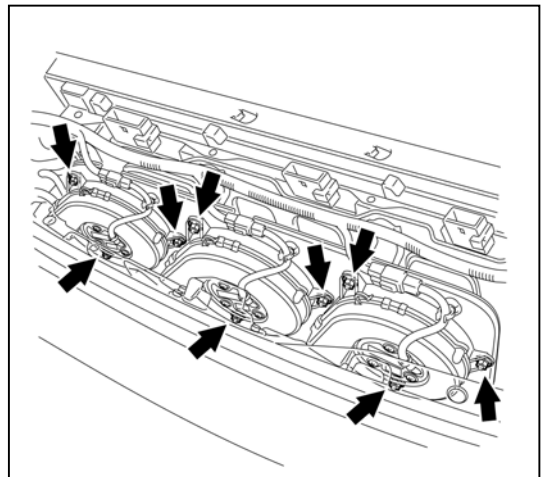

21. Disconnect the wire harness.

- (1) Disconnect the 3 connectors and 4 clamps.

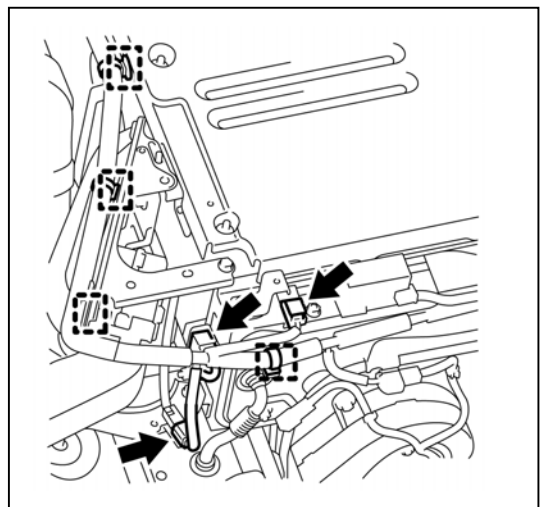

22. Remove converter cooling blower bracket.

- (1) Remove the 2 bolts and converter cooling blower bracket.

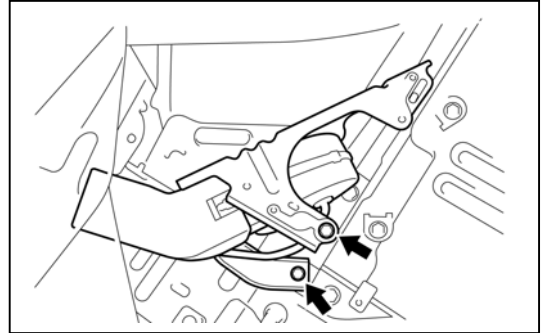

23. Remove the No. 2 converter cooling exhaust duct.

- (1) Remove the 4 clips and No. 2 converter cooling exhaust duct.

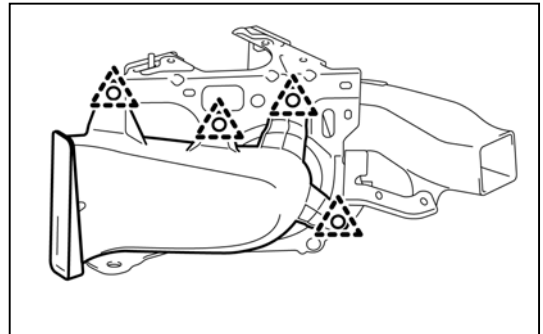

24. Remove the No. 3 converter cooling exhaust duct.

- (1) Remove the 3 clips and No. 3 converter cooling exhaust duct.

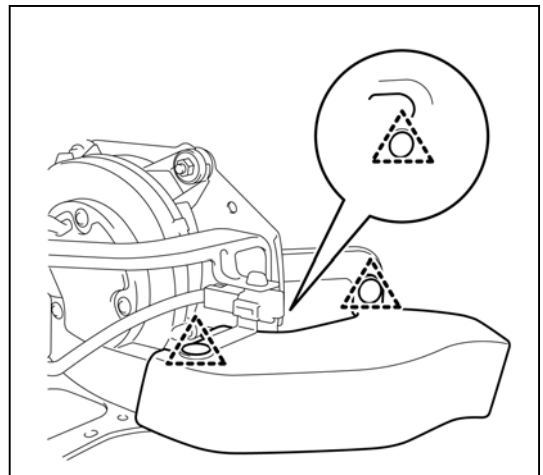

25. Remove battery cooling blower assembly (for hybrid vehicle converter).

Notice:

- **Be sure not to touch the fan part of the battery cooling blower assemblies.**
- **Do not lift the battery cooling blower assemblies using the wire harness.**

- (1) Remove the 3 nuts, clamp and battery cooling blower assembly.

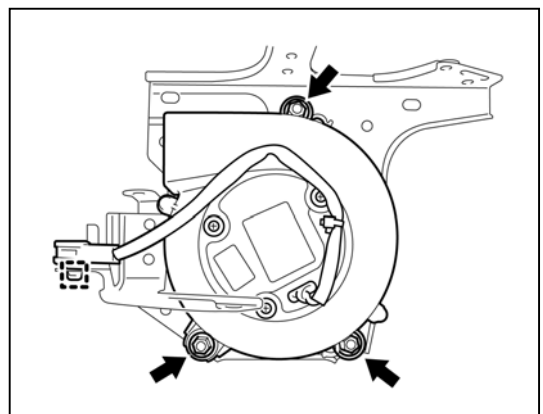

26. Remove the child restraint seat anchor bracket assembly RH.

- (1) Remove the 2 bolts and child restraint seat anchor bracket sub-assembly RH.

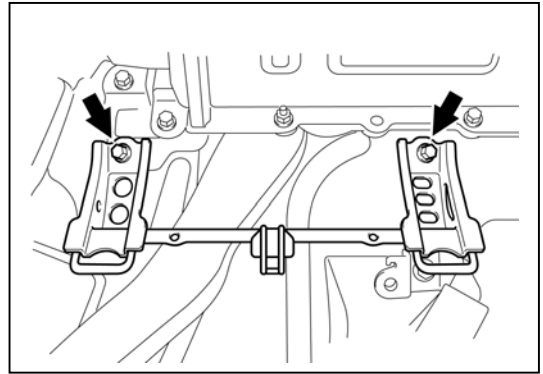

27. Remove the No. 1 hybrid battery intake duct.

- (1) Remove the clip and No. 1 hybrid battery intake duct (main).

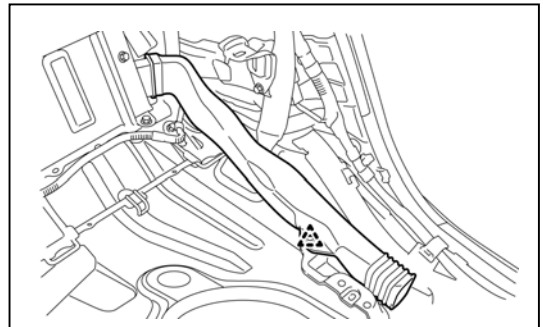

- (2) Remove the clip and No. 1 hybrid battery intake duct (sub1).

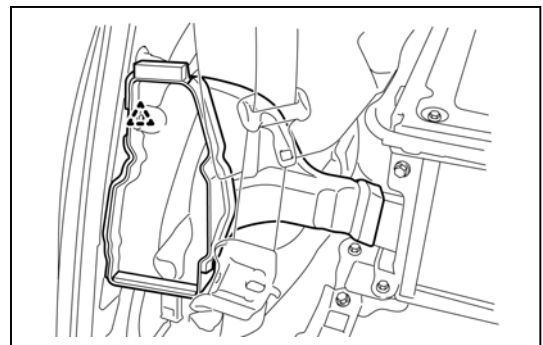

- (3) Remove the clip and No. 1 hybrid battery intake duct (sub2).

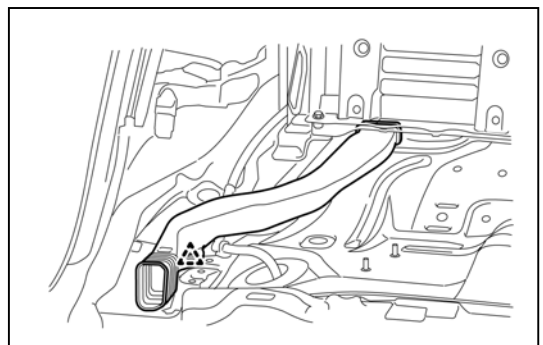

28. Remove the front hybrid cover panel.

- (1) Remove the 2 nuts and front hybrid battery cover panel.

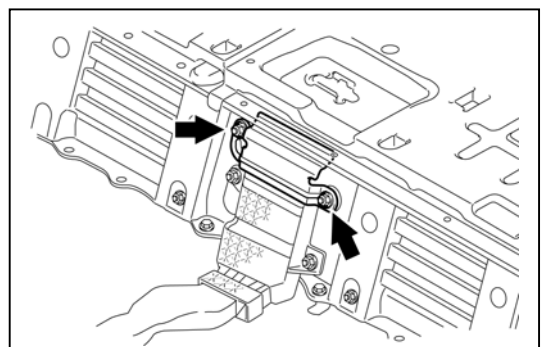

29. Remove the HV battery cover sub-assembly.

Caution:

Be sure to wear insulated gloves and protective goggles.

- (1) Separate the 2 claws and 3 clamps, and remove the indoor electrical key oscillator.
- (2) Remove the 18 nuts and HV battery cover sub-assembly.

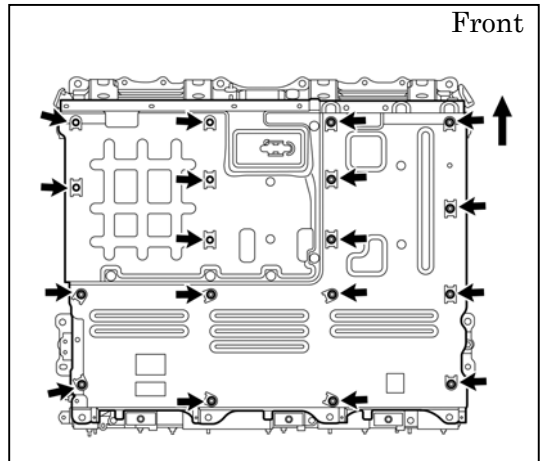
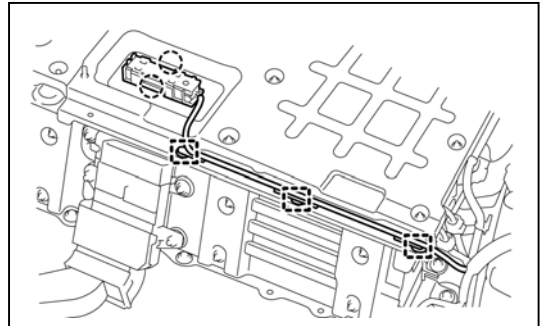

30. Disconnect the frame wire.

Caution:

Be sure to wear insulated gloves and protective goggles.

Notice:

Insulate the terminals of the removed frame wire with insulating tape.

- (1) Remove the 5 nuts and disconnect the frame wire from the hybrid junction block assembly.
- (2) Disengage the clamp, remove the nut and disconnect the frame wire from the hybrid vehicle converter.
- (3) Disconnect the connector to disconnect the frame wire from the hybrid battery charge relay.
- (4) Remove the 2 nuts and frame wire from the hybrid battery.

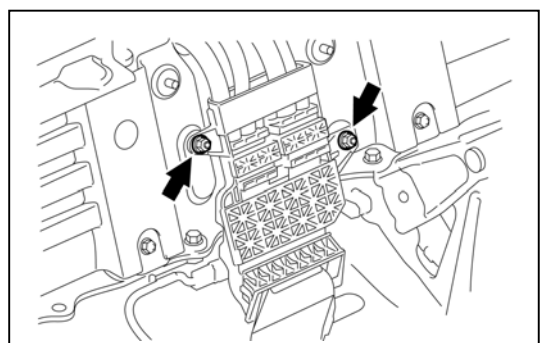
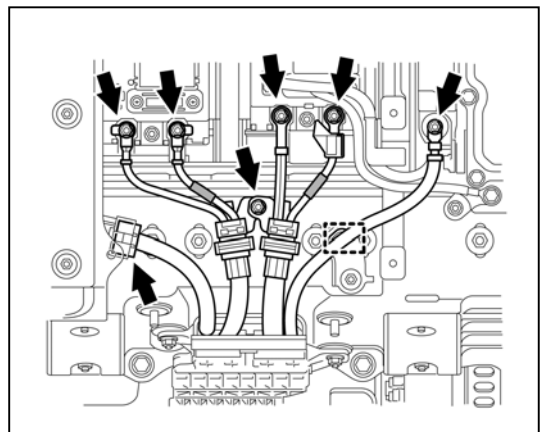

31. Remove the hybrid vehicle converter.

Caution:

Be sure to wear insulated gloves and protective goggles.

Notice:

Insulate the terminals of the removed frame wire with insulating tape.

- (1) Disengage the clamp and disconnect the connector.

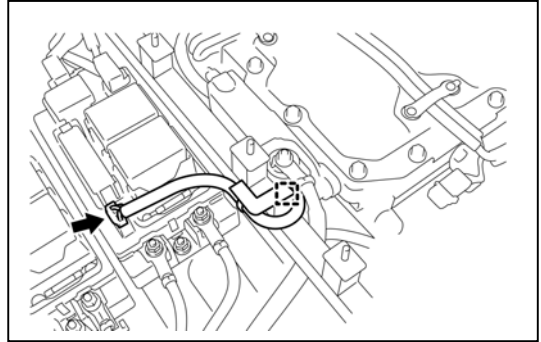

- (2) Disconnect the 2 connectors.

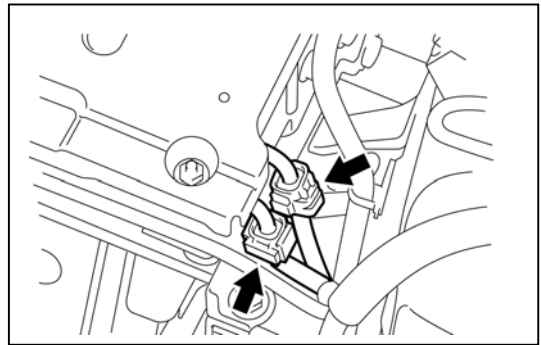

- (3) Remove the 4 nuts and hybrid vehicle converter.

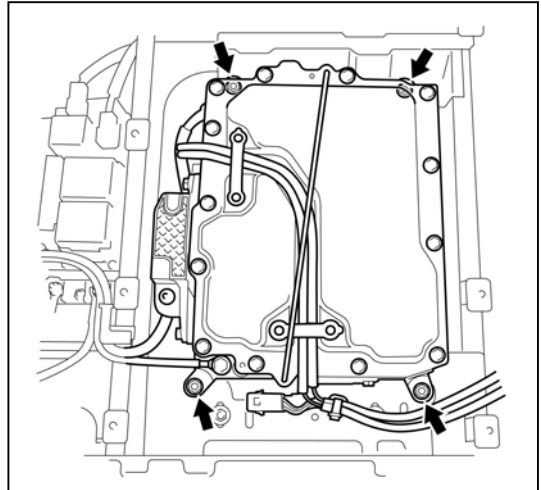

32. Remove the converter cooling exhaust duct.

Caution:

Be sure to wear insulated gloves and protective goggles.

- (1) Remove the 2 clips, guide and converter cooling exhaust duct.

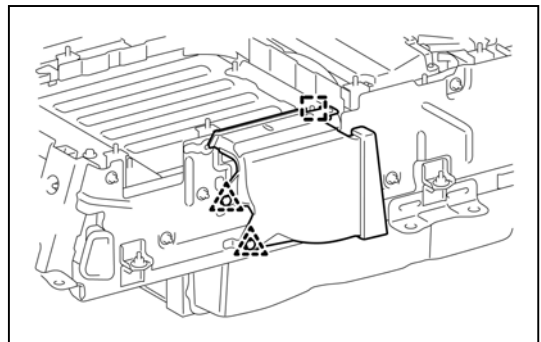

33. Install HV battery cover sub-assembly.

Caution:

Be sure to wear insulated gloves and protective goggles.

- (1) Temporarily install the HV battery cover sub-assembly with the 18 nuts to prevent any foreign objects or water from entering the HV battery.

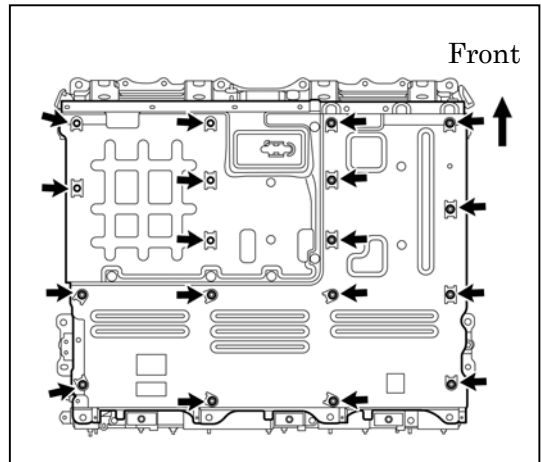

34. Remove the HV battery.

Caution:

Be sure to wear insulated gloves and protective goggles.

Notice:

Insulate the terminals of the removed frame wire with insulating tape.

- (1) Remove the 2 bolts from each back door damper stay bracket UPR.

Hint:

Have an assistant support the back door.

- (2) Rotate each back door damper stay bracket UPR upside-down as shown in the illustration and install them with the 2 bolts.

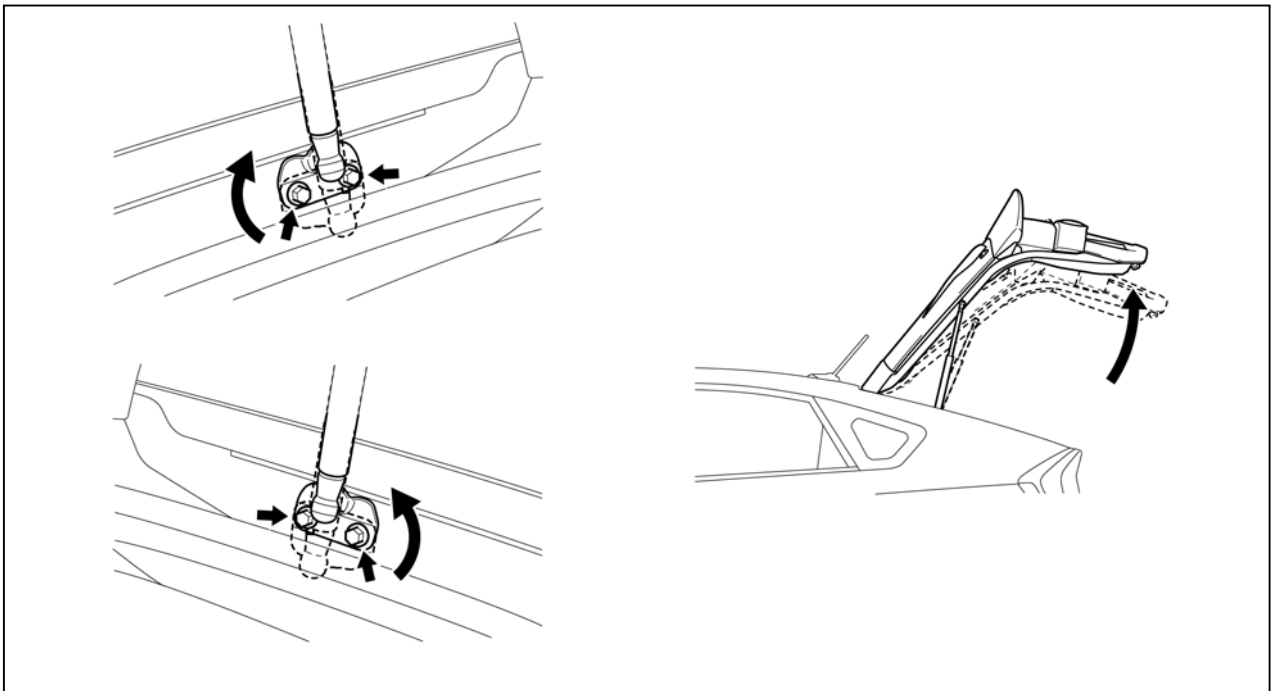

Hint:

This step is performed to provide additional clearance and prevent interference between the vehicle body and mini crane when removing or installing the HV battery.

(3) Disconnect the 4 connectors and 2 clamps.

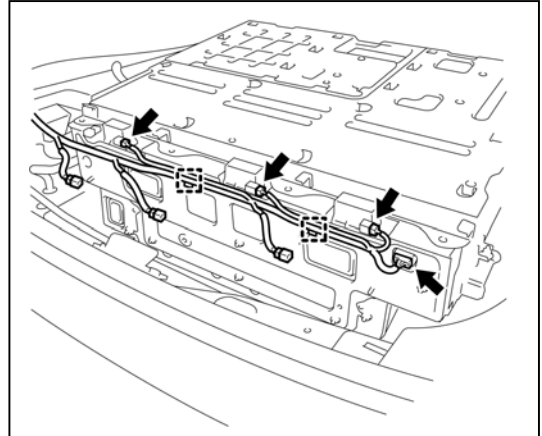

(4) Install the 4 eyebolts in the locations shown in the illustration.

Hint:

Make sure to use the eyebolts supplied with the HV battery.

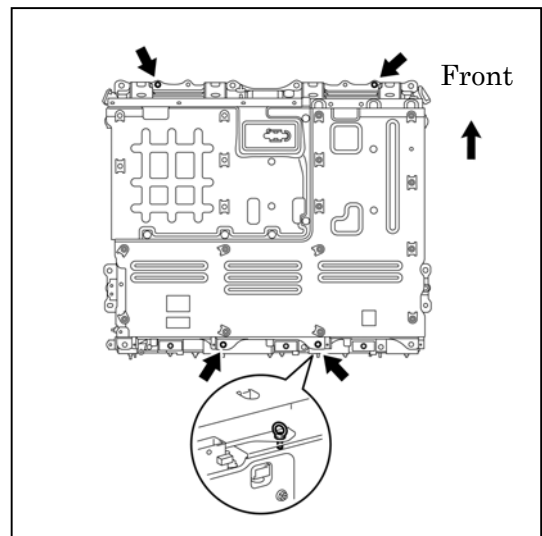

(5) Set the hooks and straps as shown in the illustration.

Notice:

Make sure to use hooks and straps that are strong enough to support the weight of the HV battery.

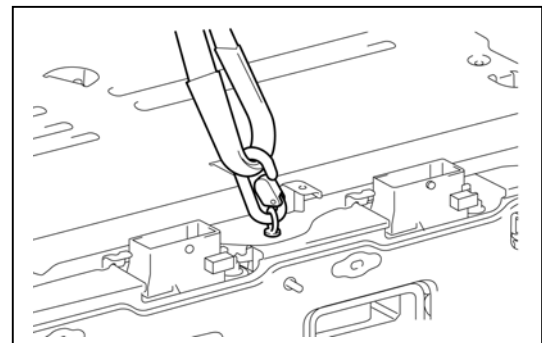

(6) Using a couple of pieces of cloth, protect the surfaces of the HV battery where it contacts the straps.

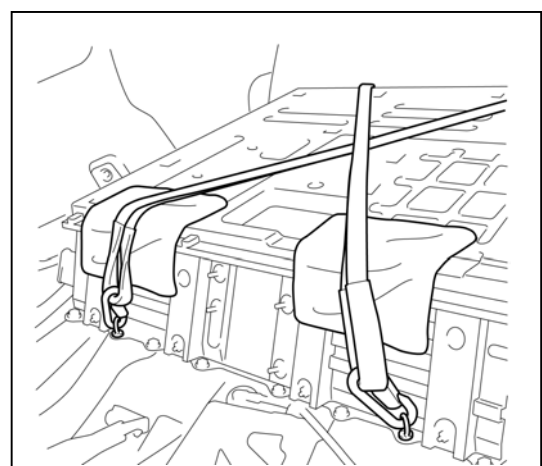

(7) Remove the 6 bolts and 2 nuts.

Hint:

- Attach tape to the feet and edges of the battery to protect tools and the vehicle body.
- Use cardboard or other similar material to protect the HV battery and vehicle body from damage.

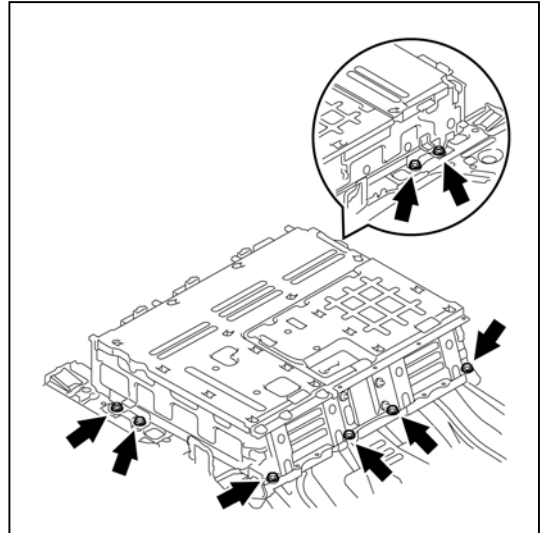

(8) Using a suitable adaptor such as straps, remove the HV battery.

Caution:

To prevent any accidents and injuries due to the weight of the HV battery, follow all specified procedures and be careful to balance the HV battery when removing or installing it.





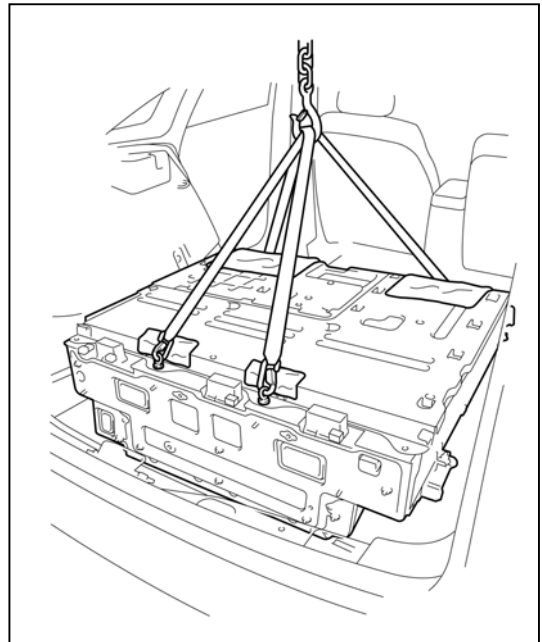

Notice:

Make sure that the HV battery does not interfere with the vehicle body during removal or installation.









HV Battery Caution Label







1. For U.S.A.

| | | | | |
|---|---------------------|--|--------|----------|
| ⚠ DANGER | |        | | C |
| High Voltage Parts Inside / Contains Organic Electrolyte | | | Li-ion | |
| <p>To avoid serious injuries, including burns and electric shocks, NEVER attempt to disassemble, open, or modify this battery unit.</p> <p align="center">-SERVICE BY QUALIFIED TECHNICIAN ONLY.-</p> <p>Do not allow electrolyte to come into contact with eyes, skin, or clothes, as blindness or severe burns may result. In case of accidental contact, rinse affected area with as much water as possible. In case of eye contact, rinse with water and seek medical attention immediately. Keep children away from this unit.</p> <p>Do not subject this battery unit to physical shock or damage, such as dropping from or being punctured by a forklift. Keep this battery pack away from fire or open flames, and never attempt to dispose of it by incineration. Exposure to excessive heat may result in electrolyte leakage, fire, and explosion. When storing the unit, ensure that it does not come into contact with water or other liquids.</p> | | | | |
| To Qualified EV Technician: | | Refer to the Repair Manual when disassembling, repairing, or replacing this battery. | | |
| HV Battery Recycling Information: | | When transporting this battery, be sure to comply with all applicable laws. Consult your dealer or the following address for replacement and disposal of this battery. | | |
| Residents of U.S.A. | | Residents of PUERTO RICO | | |
| TOYOTA MOTOR SALES U.S.A., INC. TORRANCE, CAL. 90501 Phone : 1-800-331-4331 HONOLULU, HAWAII 96813 Phone : 808-839-2273 | SERVCO PACIFIC INC. | TOYOTA DE PUERTO RICO HATO REY, PUERTO RICO Phone : 787-751-1000 | | |

2. For CANADA

| | | | | |
|---|--|--|--|-----------------|
| ⚠ DANGER | |       | | Li-ion D |
| High Voltage Parts Inside / Contains Organic Electrolyte | | Pièces à haute tension / Contient de l'électrolyte organique | | |
| <p>To avoid serious injuries, including burns and electric shocks, NEVER attempt to disassemble, open, or modify this battery unit.</p> <p align="center">-SERVICE BY QUALIFIED TECHNICIAN ONLY.-</p> <p>Do not allow electrolyte to come into contact with eyes, skin, or clothes, as blindness or severe burns may result. In case of accidental contact, rinse affected area with as much water as possible. In case of eye contact, rinse with water and seek medical attention immediately. Keep children away from this unit.</p> <p>Do not subject this battery unit to physical shock or damage, such as dropping from or being punctured by a forklift. Keep this battery pack away from fire or open flames, and never attempt to dispose of it by incineration. Exposure to excessive heat may result in electrolyte leakage, fire, and explosion. When storing the unit, ensure that it does not come into contact with water or other liquids.</p> | | | | |
| To Qualified EV Technician: | | Note au technicien qualifié: Se reporter au manuel de réparation lors du démontage, de la réparation ou du remplacement de la batterie. | | |
| HV Battery Recycling Information: | | Informations concernant le recyclage des batteries des véhicules hybrides: | | |
| When transporting this battery, be sure to comply with all applicable laws. Consult your dealer or the following address for replacement and disposal of this battery. | | Lors au transport de cette batterie, s'assurer que toutes les lois applicables sont respectées. Adressez-vous à votre concessionnaire ou à l'une des adresses suivantes pour remplacer votre batterie ou la mettre à rebut. | | |
| TOYOTA CANADA INC. ONE TOYOTA PLACE SCARBOROUGH, ONTARIO M1H 1H9 Phone: 1-888-TOYOTA-8(1-888-869-8828) URL: http://www.toyota.ca | | | | |

3. For Europe

| | | | | |
|---|--|--|--|-----------------|
| ⚠ DANGER | |       | | Li-ion B |
| High Voltage Parts Inside / Contains Organic Electrolyte | | Pièces à haute tension / Contient de l'électrolyte organique | | |
| <p>To avoid serious injuries, including burns and electric shocks, NEVER attempt to disassemble, open, or modify this battery unit.</p> <p align="center">-SERVICE BY QUALIFIED TECHNICIAN ONLY.-</p> <p>Do not allow electrolyte to come into contact with eyes, skin, or clothes, as blindness or severe burns may result. In case of accidental contact, rinse affected area with as much water as possible. In case of eye contact, rinse with water and seek medical attention immediately. Keep children away from this unit.</p> <p>Do not subject this battery unit to physical shock or damage, such as dropping from or being punctured by a forklift. Keep this battery pack away from fire or open flames, and never attempt to dispose of it by incineration. Exposure to excessive heat may result in electrolyte leakage, fire, and explosion. When storing the unit, ensure that it does not come into contact with water or other liquids.</p> | | | | |
| To Qualified EV Technician: | | Note au technicien qualifié: Se reporter au manuel de réparation lors du démontage, de la réparation ou du remplacement de la batterie. | | |
| HV Battery Recycling Information: | | Informations concernant le recyclage des batteries des véhicules hybrides: | | |
| When transporting this battery, be sure to comply with all applicable laws. Consult your dealer or your national distributor as mentioned in your Dealer Guidebook for replacement and disposal of this battery. | | Lors au transport de cette batterie, s'assurer que toutes les lois applicables sont respectées. Adressez-vous à votre concessionnaire ou réparateur agréé Toyota pour le remplacement et la mise au rebut de la batterie. | | |
|  | | | | |